

Home Theatre System
BRAVIA Theatre Quad



Model: YY2080C

Install the application on your smartphone and follow the directions on the application to set up the speaker system

Be sure to use the application to set up the speaker system even when connecting the optional speakers.



To use the speaker system with all the available functions and improved performance, update the software of the speaker system and the "Sony | BRAVIA Connect" app to the latest versions.

HT-A9M2

How to Use/Parts and Controls

[About the App Required to Use the Speaker System](#)

[Devices That Are Connected to the Speaker System](#)

[About the Help Guide Description](#)

Parts and Controls

- [Control Box](#)

- [Speakers](#)

- [Supplied Remote Control](#)

- [Remote Control Screen on the App](#)

Initial Setup

Installing the Speaker System

- [Installing the Control Box and Speakers](#)

- [Installing the Speakers on a TV Stand and Shelves](#)

- [Mounting the Speakers on a Wall](#)

[Connecting to a TV](#)

[If Your TV Has the S-CENTER SPEAKER IN Jack](#)

[Connecting an AV Device](#)

[Connecting to an AC Outlet \(Mains\)](#)

[Performing Initial Setup with the “Sony | BRAVIA Connect” App](#)

[If the Speakers Are Not Connected Correctly](#)

Listening to Music/Sound

[Listening to TV Sound](#)

[Playing the Connected AV Device](#)

[Adjusting Sound Quality](#)

Listening to Music/Sound with the BLUETOOTH® Function

- [Listening to Music by Pairing the BLUETOOTH Device that is Connected for the First Time](#)

- [Listening to Music from the Paired BLUETOOTH Device](#)

[Setting the Wireless Function to On or Off](#)

Enjoying 360 Reality Audio

- [About 360 Reality Audio](#)

- [Playing 360 Reality Audio Content from the Connected AV Device](#)

Enjoying Music on a Network

[Using Spotify](#)

[Using AirPlay](#)

Using the Speaker System by Interlocking with a TV

[Operating the Speaker System by Interlocking with a TV \(Control for HDMI Function\)](#)

[Operating the Speaker System by Interlocking with a TV Compatible with the "BRAVIA Sync" Function](#)

Changing the Settings with the App

[\[Wireless Speaker Settings\]](#)

[\[Sound Settings\]](#)

[\[HDMI Settings\]](#)

[\[Bluetooth Settings\]](#)

[\[System Settings\]](#)

[\[Network Settings\]](#)

[\[Easy Initial Setup\]](#)

[\[Software update\]](#)

[Saving Power in Standby Mode](#)

Troubleshooting

[Troubleshooting](#)

[Resetting the Speaker System](#)

Additional Information

[Specifications](#)

[Supported Audio Formats](#)

[Supported HDMI Video Formats](#)

[Trademarks](#)

[Licenses](#)

[Notes on Use](#)

[Customer Support Website](#)

Home Theatre System
BRAVIA Theatre Quad

About the App Required to Use the Speaker System

Use a smartphone with the “Sony | BRAVIA Connect” app installed to perform initial setup and operations as well as configure the settings on the speaker system.

Be sure to use the application to set up the speaker system even when connecting the optional speakers. Install the “Sony | BRAVIA Connect” app on your smartphone.



An Internet connection is required to use the speaker system.

To use the speaker system, connect the smartphone on which the app is installed to the same network as the speaker system.

The app allows you to perform the following operations and setup.

- Initial setup of the speaker system, including network connection, surround sound optimization, etc.
- Operations such as volume adjustment, input selection, etc.
- Change the settings of the speaker system to the desired settings
- Connect the supplied speakers and optional subwoofer and perform initial setup
- Update the software of the speaker system to the latest version
- Check the support information and latest update information

The supplied remote control can only be used to perform operations and change settings that are frequently used when you view content.

Note

- An account and sign-in are required to use the app.
- If you do not use the app or the speaker system for more than 30 days, you may need to re-register the speaker system on the app.

Related Topic

- [Supplied Remote Control](#)
- [Remote Control Screen on the App](#)

TP1001053982

Devices That Are Connected to the Speaker System

The speaker system supports object-based audio formats such as Dolby Atmos and DTS:X.

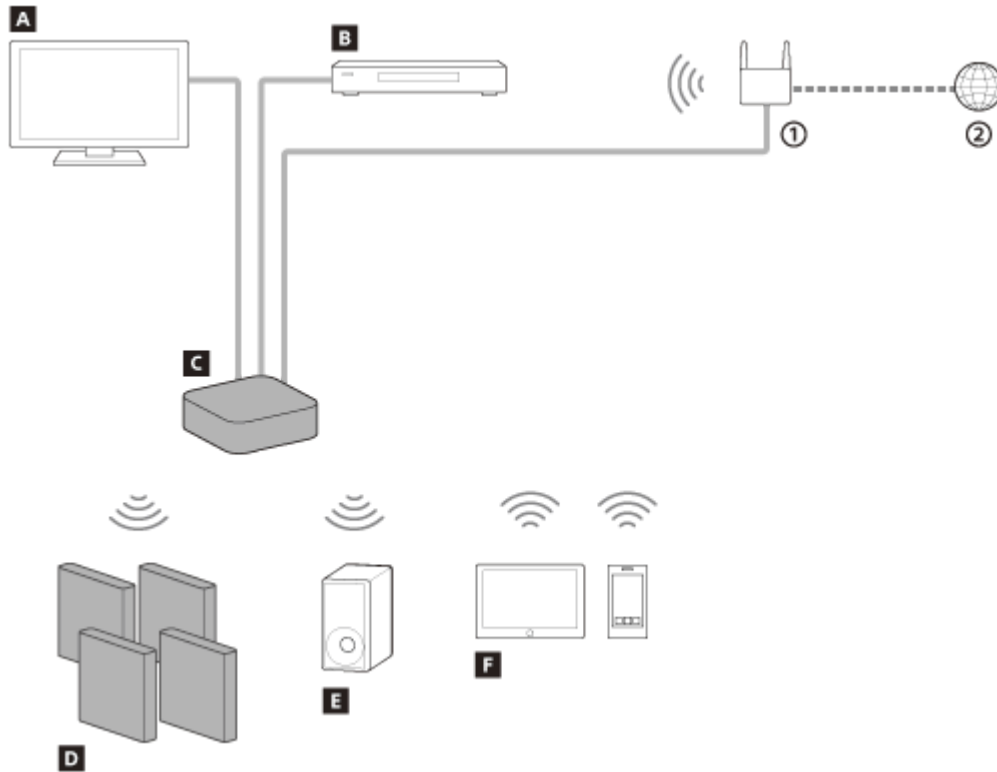

- ① Wireless LAN router
- ② Internet

A TV

The speaker system can be used to play TV sound by connecting the control box and TV using an HDMI cable.

[Listening to TV Sound](#)

B AV device (Blu-ray Disc™ player, set-top box, cable box, satellite box, gaming console, etc.)

The speaker system can be used to play AV device sound by connecting the control box and AV device using an HDMI cable.

The speaker system can also play the sound of an AV device that is connected to the TV.

[Playing the Connected AV Device](#)

C Control box

Connect a TV or AV device to enjoy sound through the speakers that are connected wirelessly.

D Supplied speakers

Connect wirelessly to the control box to play the speaker system sound.

E Optional subwoofer

By using the app, optional subwoofers can be connected with the speaker system and configured.

For the supported optional subwoofers, see the Sony website.

F Mobile device

The speaker system can be used to play mobile device sound by connecting the speaker system and mobile device using the BLUETOOTH function.

The speaker system can also be used to stream music by connecting a mobile device to the same network as the speaker system.

[Listening to Music by Pairing the BLUETOOTH Device that is Connected for the First Time](#)

TP1001053981

5-049-832-11(4) Copyright 2024 Sony Corporation

About the Help Guide Description

About the description of operations

This Help Guide explains operations based on the following assumptions.

- Both the speaker system and the “Sony | BRAVIA Connect” app have the latest version of software.
- The speaker system is connected to a TV that is compatible with eARC or ARC using an HDMI cable, and the Control for HDMI functions of the speaker system and TV are enabled.
- The setup of the speaker system and TV(*) has been completed on following the “Sony | BRAVIA Connect” app screen.

* If you are using an app-compatible BRAVIA, both the speaker system and BRAVIA can be controlled with the remote control screen on the app. If you are using other TVs, only the speaker system can be controlled with the remote control screen on the app.

About the wording displayed on the app

- The letters in [] (brackets) indicate the wording that appears on the “Sony | BRAVIA Connect” app screen.

TP1001669358

Control Box

Front

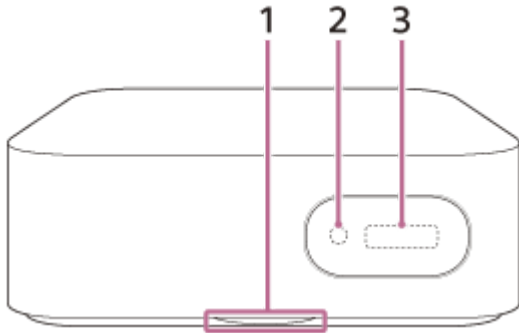

1. Status LED

Indicates the speaker system status.

- Flashing in blue: Registering the speaker system.
- Flashing slowly in white: Initial setup is not complete or the speaker system is not connected to a network.
- Turned off: Initial setup is complete and the speaker system is connected to a network.

2. Remote control sensor

Use the supplied remote control while pointing it at the remote control sensor on the control box to operate the speaker system.

3. Front panel display

Rear

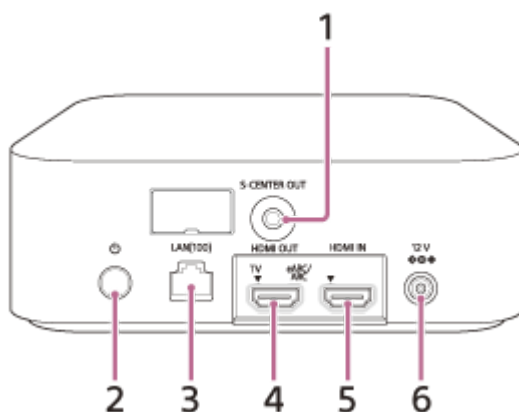

1. S-CENTER OUT jack

2. ⏻ (Power)

Turns on the speaker system. If you press this button when the speaker system is turned on, the speaker system is set to standby mode.

Press and hold this button for more than 10 seconds to reset the control box.

3. LAN(100) jack

4. HDMI OUT (TV eARC/ARC) jack

Use an HDMI cable to connect a TV that has an HDMI input jack. The speaker system is compatible with eARC and ARC. ARC is a feature that sends TV sound from the HDMI jack on the TV to an AV device such as the speaker system via an HDMI cable. eARC is an advanced version of ARC that enables transmission of object-based audio and multi-channel LPCM content that cannot be transmitted with ARC.

5. HDMI IN jack

6. DC IN terminal

Related Topic

- [Connecting to a TV](#)
- [If Your TV Has the S-CENTER SPEAKER IN Jack](#)
- [Connecting an AV Device](#)
- [Connecting to an AC Outlet \(Mains\)](#)
- [Resetting the Speaker System](#)

TP1001053980

Speakers

Front

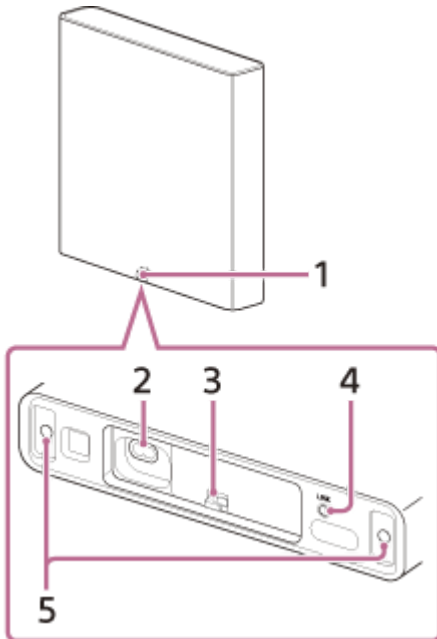

1. Power indicator

Indicates the speaker's connection status with the control box and whether the speaker is on and off.

- Green
 - Lit up: The speaker is connected to the control box.
 - Flashing slowly: The speaker is attempting to connect to the control box.
 - Flashing twice repeatedly: The speaker is attempting to connect to the control box after LINK was pressed. Follow the instructions on the app.
- Red
 - Lit up: The speaker is in network standby mode(*).
 - * The speaker maintains a connection with the control box and can be activated by interlocking with the control box.
- Amber
 - Flashing/lit up: The speaker is updating its software.
- Turned off
 - The speaker is turned off.

2. AC inlet

3. Cable holder

4. LINK

When the speaker is turned on:

- Press: Press this button when the control box and speakers do not connect properly with the “Sony | BRAVIA Connect” app. Follow the instructions on the app.
- Press and hold for 2 seconds: Turns off the speaker.
- Press and hold for more than 10 seconds: Resets the speaker.

When the speaker is turned off:

- Press: Turns on the speaker.

5. Speaker fixing hole

Rear

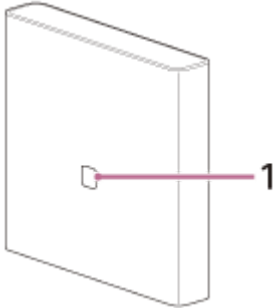

1. Hole for wall hook attachment/hole for the general speaker stand

Note

- Remove the hole cover to use the hole. Keep the hole cover and the screw behind the cover for use when you do not mount the speaker on a wall or stand.
- Sony shall not be held responsible for accidents or damage caused by improper installation, lack of installation strength, misuse, or natural disaster.

Related Topic

- [Connecting to an AC Outlet \(Mains\)](#)
- [Resetting the Speaker System](#)

TP1001174823

Supplied Remote Control

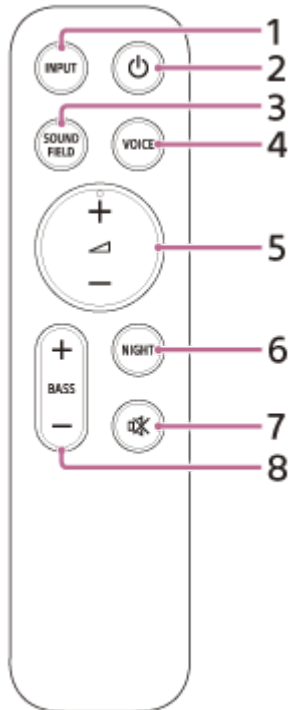

1. INPUT (Input)

Used to select the input for playback on the speaker system.

Press the button to display the currently selected input. Press the button again to select the input. The input is switched each time you press this button.

2. (Power)

Switches between power on and standby on the speaker system.

3. SOUND FIELD (Sound field)

Turns on/off the surround sound effect on the speaker system.

4. VOICE (Voice mode)

Turns on/off the voice mode on the speaker system.

When a Sony TV compatible with the linkage function of the speaker system is connected, the voice zoom is turned on/off instead of the voice mode by selecting TV input on the speaker system.

5. (Volume) +(*)/-

Used to adjust the volume of the speaker system.

6. NIGHT (Night mode)

Turns on/off the night mode on the speaker system.

7. (Muting)

Temporarily turns off the sound on the speaker system.

8. BASS (Bass level) +/-

Used to adjust the volume of the bass sound or optional subwoofer.

*  (Volume) + has a tactile dot. Use it as a guide during operation.

About the replacement of batteries for the supplied remote control

If the speaker system does not respond when operating with the supplied remote control, replace the two batteries with new batteries.

Use R03 or LR03 (size AAA) batteries for replacement.

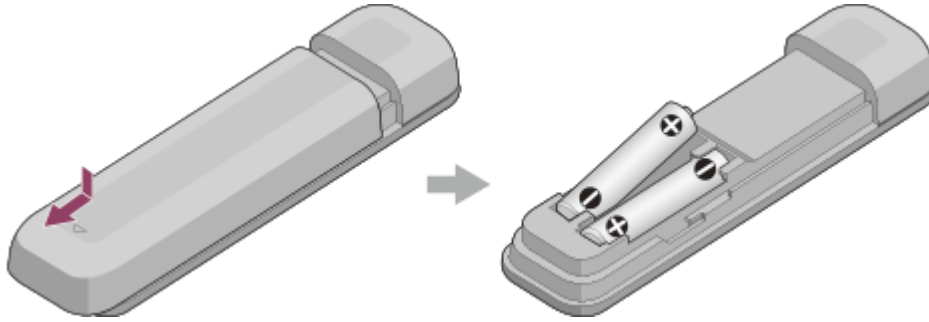

If the remote control does not work properly

- Point the remote control at the remote control sensor on the control box.
- Remove any obstructions between the remote control and the control box.
- Check that the + and - of the battery are in the correct orientation.
- Replace both batteries in the remote control with new ones if they are older batteries.
- Check that the correct button on the remote control is being pressed.

Related Topic

- [Adjusting Sound Quality](#)

TP1001053979

Home Theatre System
BRAVIA Theatre Quad

Remote Control Screen on the App

There are two types of remote control screens on the app.

Remote control screen that can only operate the speaker system

This screen is displayed when a TV that is not compatible with the app is connected using the HDMI cable.

Remote control screen that can operate the speaker system and BRAVIA

This screen is displayed when an app-compatible BRAVIA is connected using the HDMI cable.

The following items that can be used to operate the speaker system are displayed in [Remote], [Picture & Sound], [Audio output], and [Settings]. If the TV is not turned on, a remote control screen that can only operate the speaker system will appear.

Items on the remote control screen on the app

- **Playback information/input switching area**

The currently selected input, etc. appears on the upper part of the screen. The following information and operations are displayed by tapping this area.

- Playback meta information: Name, artist, album, length, etc. of the song that is currently playing.
- Stream Info: Input signal frequency, etc.
- Audio format: Audio format of input signal (Dolby Atmos, DTS, etc.), number of channels, etc.
- Name of the BLUETOOTH device connected to the speaker system
- Playback controls for the BLUETOOTH device
- Input selection(*)

* When a TV compatible with the app is connected to the speaker system using an HDMI cable, TV input can also be selected.

- [ (Power)]

Sets the speaker system to standby mode when this is tapped while the speaker system is turned on.

- [Night mode]

Turns on/off the night mode on the speaker system.

- [Sound field]

Turns on/off the surround sound effect on the speaker system.

- [Voice mode]

Turns on/off the voice mode on the speaker system.

- [Voice Zoom]

This function is enabled when a Sony TV compatible with the linkage function of the speaker system is connected. When TV input is selected on the speaker system, the voice zoom works instead of the voice mode.

- [Volume]

Used to adjust the volume of the speaker system.

- [Rear level]

Used to adjust the volume of the rear speakers.

- [Bass level]

Used to adjust the volume of the bass sound or optional subwoofer.

- **[Audio]**

When a dual audio (dual mono) signal is input to the speaker system, the audio you want to hear can be selected.

- **[Viewing Position]**

The sound field can be optimized according to the viewing position. This function cannot be used if the viewing position is not measured accurately by the initial setup or [Sound Field Optimization](*).

* Displayed by tapping [Settings] - [Sound Settings] - [Sound Field Optimization] on the remote control screen on the app.

- **[Settings]**

Used to configure the settings of the speaker system.

Note

- If the control response is poor, check the Wi-Fi connection between the smartphone and the speaker system.

Related Topic

- [Adjusting Sound Quality](#)

TP1001669359

5-049-832-11(4) Copyright 2024 Sony Corporation

Installing the Control Box and Speakers

1 Choose an installation method for the control box and speakers.

They can be installed on a TV stand or shelves, etc. or mounted on the wall.

Example of speakers installed on a TV stand and shelves:

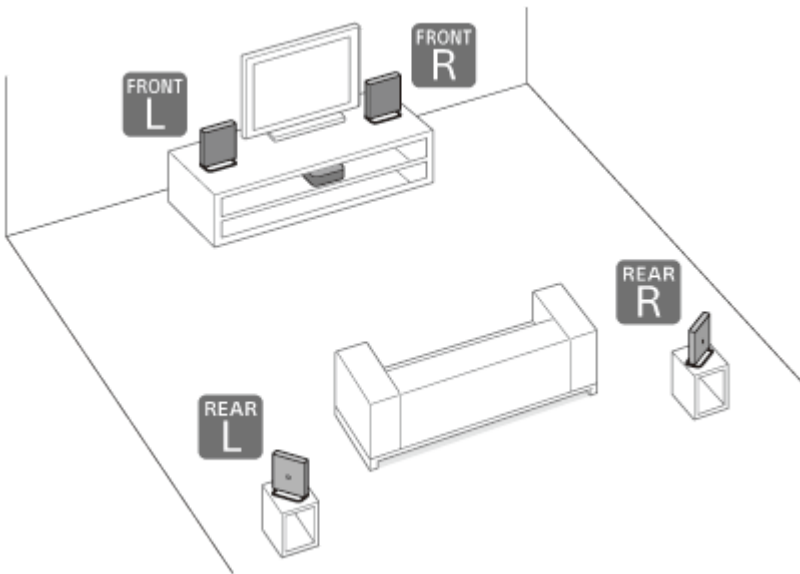

Example of speakers mounted on the wall:

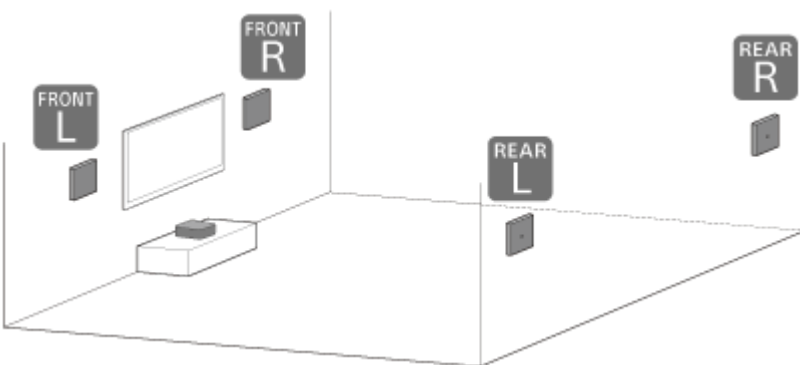

Note



- Do not install the speakers in a cabinet or directly under the ceiling. Doing so may obstruct the sound output from the top of the speaker.
- Do not place metal objects near the speaker system. Wireless functions may become unstable.

2 Choose an installation position.

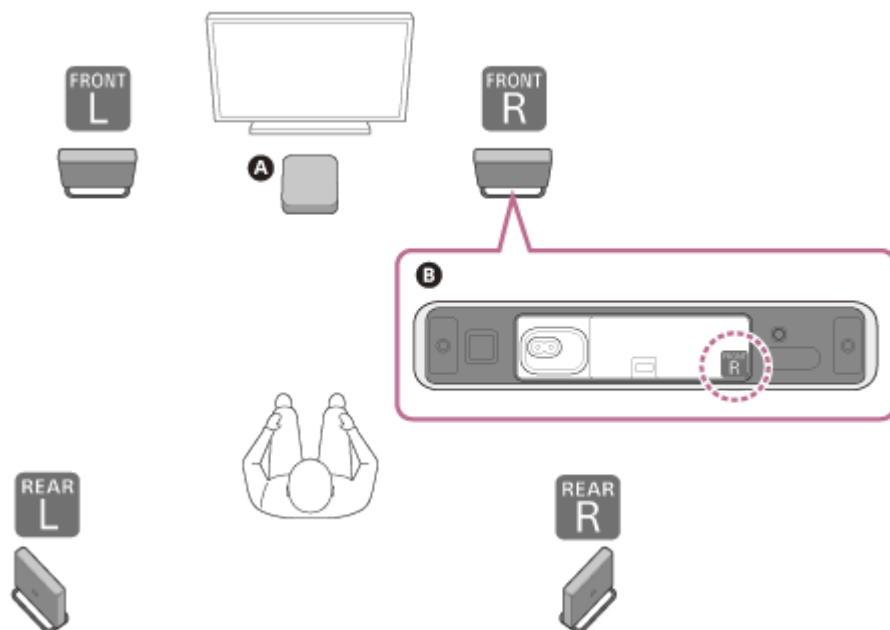

1. Install the control box on or in a shelf where the front panel display is not covered.
2. Determine the installation position of the 4 speakers by checking the labels on the bottom of the speakers. For better surround sound, install the 4 speakers to surround your listening position and install the front speakers on the left and right sides of the TV.

A Control box

B Bottom of the speaker

FRONT L Front left speaker

FRONT R Front right speaker

REAR L Rear left speaker

REAR R Rear right speaker

Note

- Before connecting the speaker system, disconnect the AC power cords (mains leads) of the TV and AV devices from the AC outlets (mains). Reconnect the AC power cords (mains leads) to the AC outlets (mains) after connecting the speaker system to the TV or AV devices.
- If the installation position of the speakers or the arrangement of the room has changed, reoptimize the sound field by accessing [Settings] - [Sound Settings] - [Sound Field Optimization] on the remote control screen on the app.

If the sound from the speakers skips

This may be improved by changing the installation positions or settings of the speakers.

If you feel that the TV screen is out of alignment with the position from which you hear dialog, etc.

If there is a large difference in the distance between the TV and the front left speaker and the TV and the front right speaker, accessing [Settings] - [Sound Settings] and performing [Sound Field Optimization] on the remote control screen on the app may improve this issue.

Using with an optional subwoofer

If you have not yet started setting up the speaker system, use the “Sony | BRAVIA Connect” app to start the setup. During the setup process, the app will guide you in connecting an optional subwoofer. No sound is output from the subwoofer if the setup is not completed on the app.

If you have already completed the setup of the speaker system, check [Settings] - [Wireless Speaker Settings] - [Wireless Speaker Connection] on the remote control screen on the app.

If the sound from the optional subwoofer skips, this may be improved by changing the subwoofer installation position or settings.

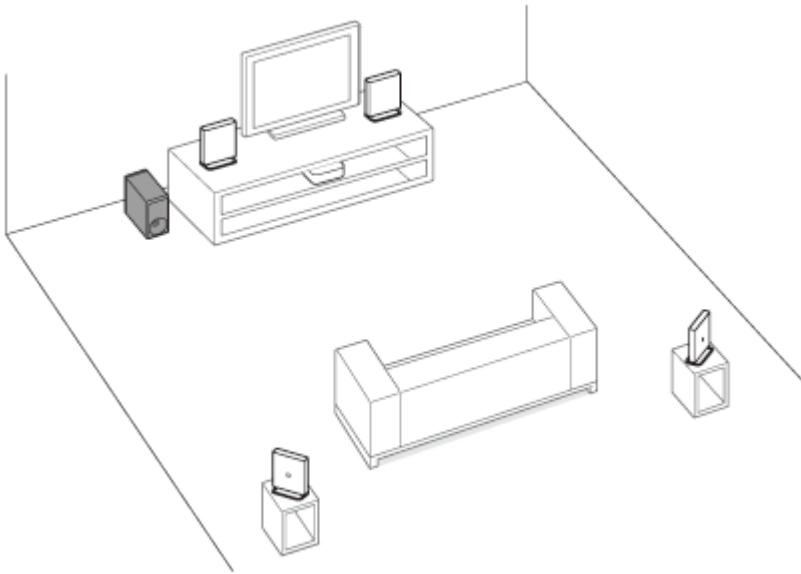

Note

- A software update may be required when using an optional subwoofer.

If changing the installation method or position of the speaker system or optional subwoofer

Perform [Sound Field Optimization](*) on the app in the following cases.

- Changing the position and installation method of the speaker system as well as the optional subwoofer
- When changing your daily viewing position
- When changing the viewing environment, such as changing the layout of furniture

* Displayed by tapping [Settings] - [Sound Settings] - [Sound Field Optimization] on the remote control screen on the app.

Related Topic

- [\[Sound Settings\]](#)

TP1001174824

Installing the Speakers on a TV Stand and Shelves

Note

- Do not install the speakers in a cabinet or directly under the ceiling. Doing so may obstruct the sound output from the top of the speaker.
- Do not install speakers near metal objects. Wireless functions may become unstable.
- Do not place any obstacles between the speakers.

1 Assemble the table stand by fitting the table stand legs (supplied) into the common base (supplied).

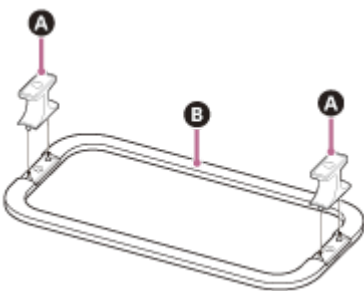

- A** Table stand legs
- B** Common base

2 Connect the AC power cord (mains lead) for the speaker (supplied) to the speaker.

Fix the AC power cord (mains lead) that is connected to the speaker to the cable holder on the bottom of the speaker.

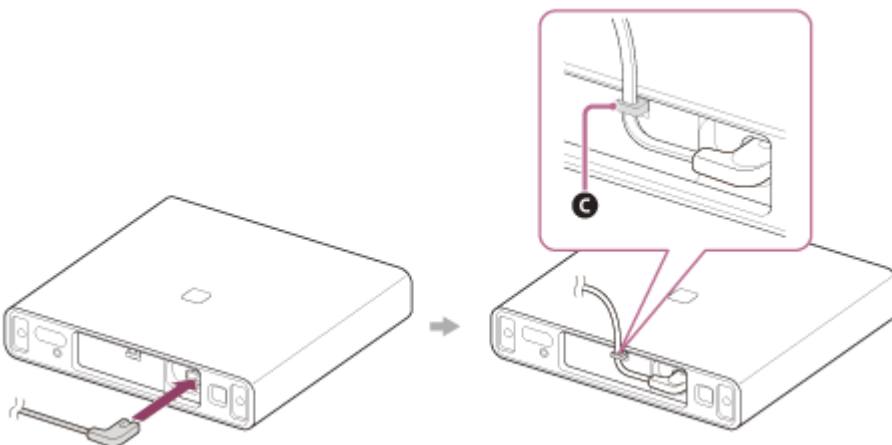

- C** Cable holder

Note

- When installing the speaker, work on a smooth surface such as a table. Working on materials with ridges or with edges to catch onto may damage the speaker.

- 3 Place the table stand assembled in step 1 onto the bottom of the speaker and secure it with the table stand screws (supplied).

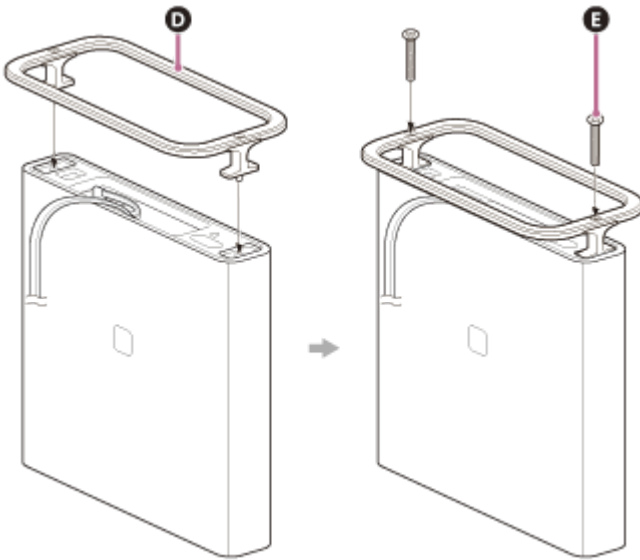



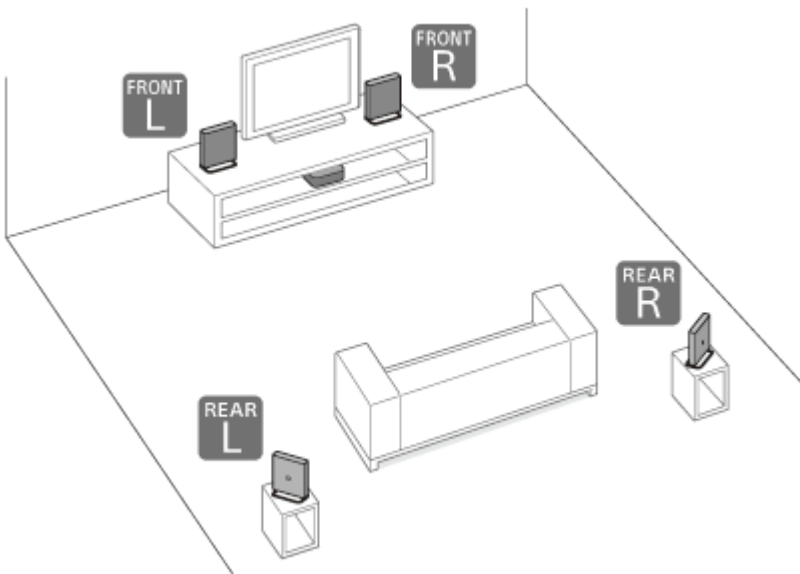

- D Table stand
- E Table stand screw

- 4 Check the intended installation positions of the speakers and install the speakers.



Check the label on the bottom of the speaker to make sure it matches the speaker's installation position.

-  Front left speaker
-  Front right speaker
-  Rear left speaker
-  Rear right speaker

- 5 Connect the AC power cord (mains lead) for the speaker that is connected to the speaker to an AC outlet (mains).

Related Topic

- [Connecting to an AC Outlet \(Mains\)](#)

Mounting the Speakers on a Wall

Note

- Make sure to use the supplied wall mounting brackets when mounting the speakers on a wall. Do not mount the speakers directly onto a wall. Doing so can cause the temperature inside the speaker to rise considerably, and this may cause damage to the speaker or malfunction.
- Prepare screws (not supplied) that are suitable for the wall material and stability. The screw may damage the wall depending on the wall material.
- Fasten the screws securely in the wall beam.
- Hang the wall mounting brackets flat against the reinforced wall.
- Ask a Sony dealer or licensed contractor to install the speakers securely with full consideration of safety.
- Sony shall not be held responsible for accidents or damage caused by improper installation, lack of installation strength, misuse, or natural disaster.
- Do not install the speakers directly under the ceiling. Doing so may obstruct the sound output from the top of the speaker.
- Do not install speakers near metal objects. Wireless functions may become unstable.
- Do not place any obstacles between the speakers.

1 Prepare 16 screws (not supplied) that are suitable for the holes on the wall mounting brackets.

4 screws are required for each speaker.

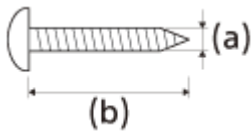

(a) 4 mm (3/16 in)

(b) Longer than 30 mm (1 3/16 in)

2 Remove the cover on the rear of the speaker.

Flip the cover open downwards, remove the screw with a screwdriver, and remove the cover.

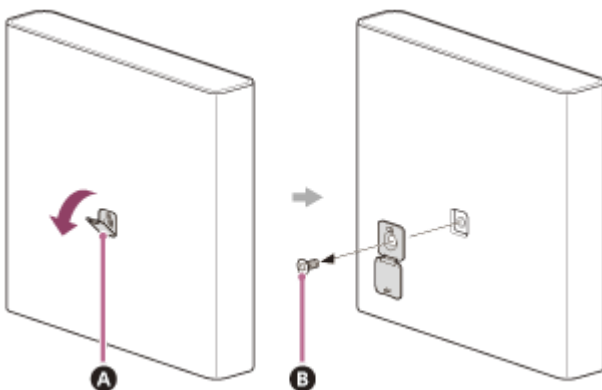

A Cover

B Screw

Note

- When installing the speaker, work on a smooth surface such as a table. Working on materials with ridges or with edges to catch onto may damage the speaker.

3 Attach the wall hook (supplied) to the speaker.

Use the screw that was removed in step 2.

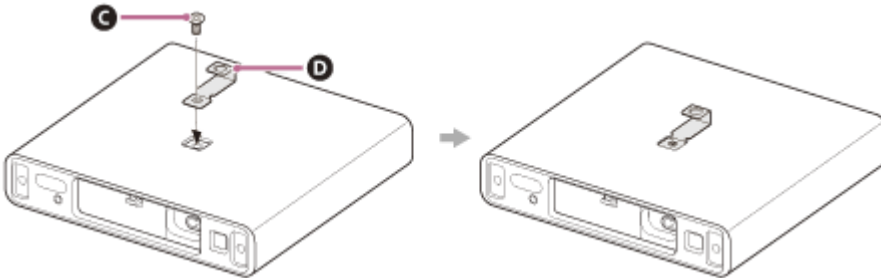

- C** Screw
- D** Wall hook

4 Connect the AC power cord (mains lead) for the speaker (supplied) to the speaker.

Fix the AC power cord (mains lead) that is connected to the speaker to the cable holder on the bottom of the speaker.

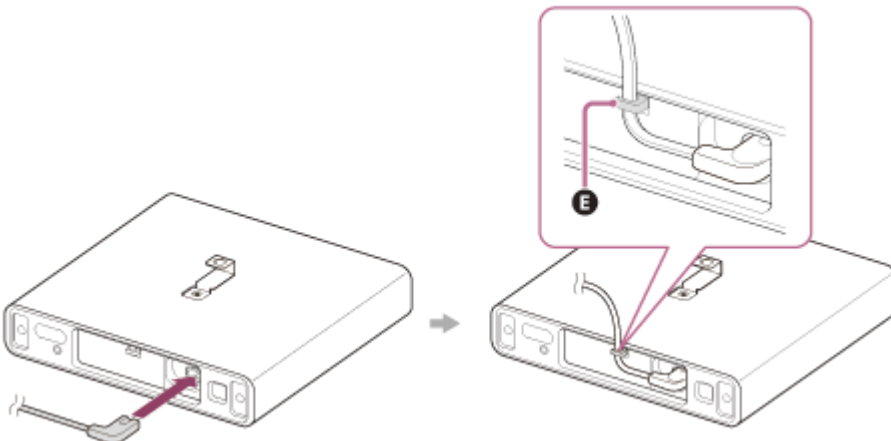

- E** Cable holder

5 Insert the pins of the wall bracket (L) and (R) (supplied) into the holes of the common base (supplied) to assemble the wall mounting bracket.

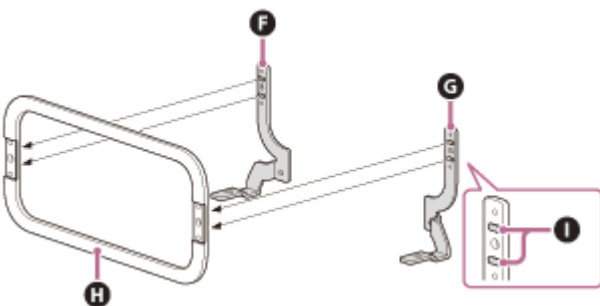

- F** Wall bracket (L)
- G** Wall bracket (R)
- H** Common base
- I** Pins

6 Decide on the wall mounting position for the speaker and install the wall mounting bracket that was assembled in step 5 for that position.

Install the wall mounting bracket flat against the wall. Secure the 4 locations indicated with the 4 screws (not supplied) that were prepared in step 1.

To avoid dropping the wall bracket, hold down the wall mounting bracket while installing.

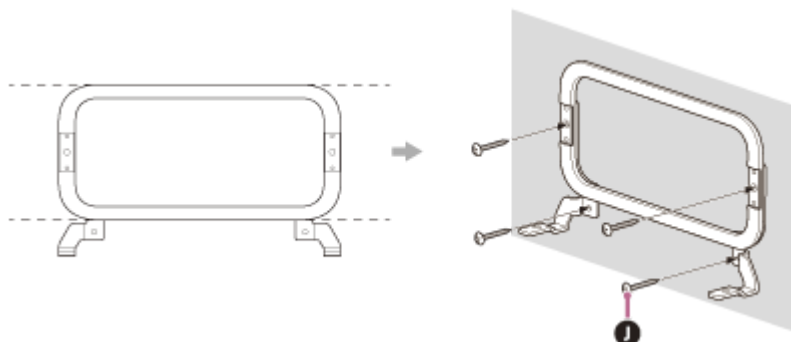



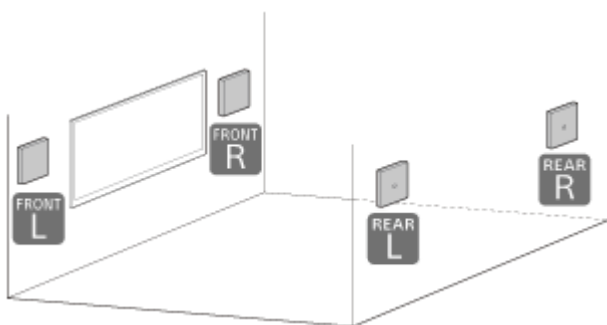

J Screws (not supplied)

7 Confirm the speaker types.



Check the label on the bottom of the speaker to make sure it matches the speaker's installation position.

- : Front left speaker
- : Front right speaker
- : Rear left speaker
- : Rear right speaker

8 Hang the speaker on the wall mounting bracket.

Hang the wall hook on the rear of the speaker on the wall mounting bracket.

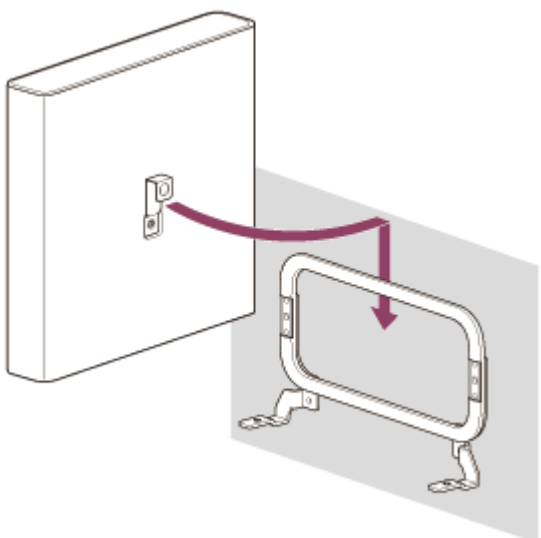

- 9 Align the positions of the screw holes on the bottom of the speaker with the holes on the wall mounting bracket, then fix the speaker to the wall mounting bracket by fastening the screws (supplied) securely.

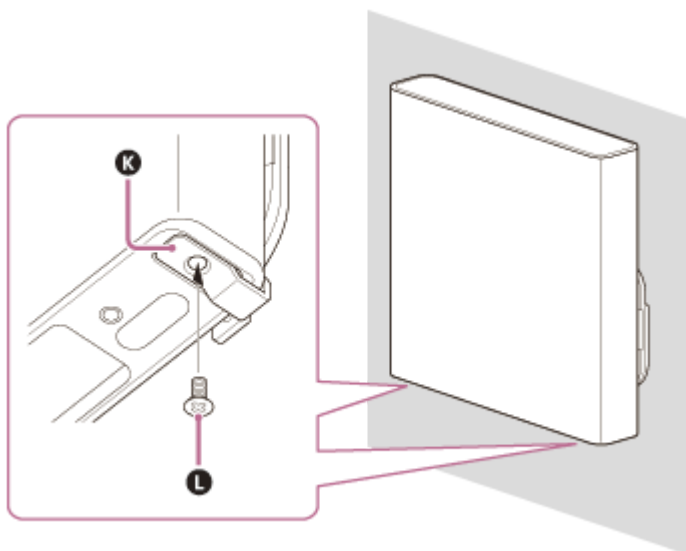

- K** Wall mounting bracket
- L** Screw

- 10 Connect the AC power cord (mains lead) for the speaker that is connected to the speaker to an AC outlet (mains).

Note

- Keep the cover that is removed in step 2 for covering the screw hole when you do not mount the speaker on a wall.

Related Topic

- [Connecting to an AC Outlet \(Mains\)](#)

TP1001053976

Connecting to a TV

- 1 Connect an HDMI IN jack compatible with ARC/eARC on the TV and the HDMI OUT (TV ARC/eARC) jack on the speaker system using the HDMI cable (supplied).

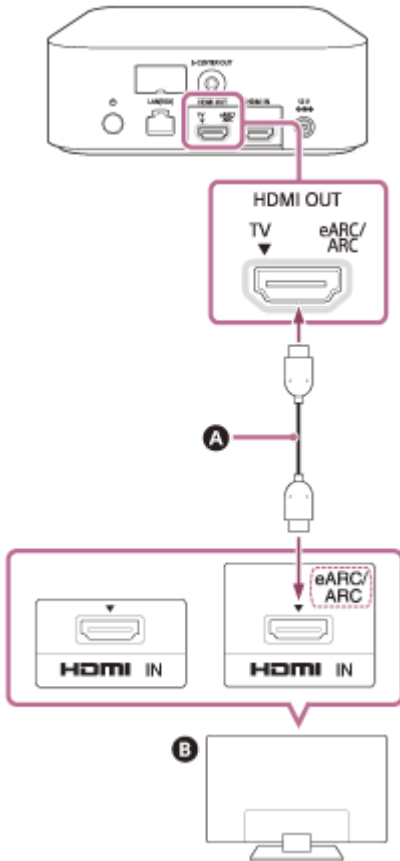

- A** HDMI cable (supplied)
- B** TV

- 2 Change the TV settings so that TV sound can be output from the speaker system.

Depending on your TV, this may be set automatically when the speaker system is connected. For details, refer to the operating instructions of your TV.

- 3 Enable eARC on both the speaker system and the TV.

If the TV that is connected to the speaker system is compatible with eARC/ARC, the eARC function is available. To enjoy higher quality audio formats such as Dolby Atmos played on an external device connected to the TV, check that the eARC setting is enabled on the speaker system and TV.

- eARC setting for the TV: Refer to the operating instructions of your TV.
- eARC setting for the speaker system: The setting is enabled by default.

Note

- Check that the connectors are firmly inserted.

- Enable the Control for HDMI function on the TV. If the Control for HDMI function on the TV is not enabled, the speaker system does not output TV sound.
- By enabling the eARC function on the TV, some features on the TV may become limited. For instance, system sounds and voice response may not be output. For details, refer to the operating instructions of your TV.

TP1001174826

5-049-832-11(4) Copyright 2024 Sony Corporation

If Your TV Has the S-CENTER SPEAKER IN Jack

The TV can output the center part of the speaker system sound if the speaker system is connected to the TV using the following method.

- 1 Connect the speaker system and TV using the HDMI cable (supplied).
- 2 Connect the S-CENTER SPEAKER IN jack on the TV and the S-CENTER OUT jack on the speaker system using the TV center speaker mode cable (supplied).

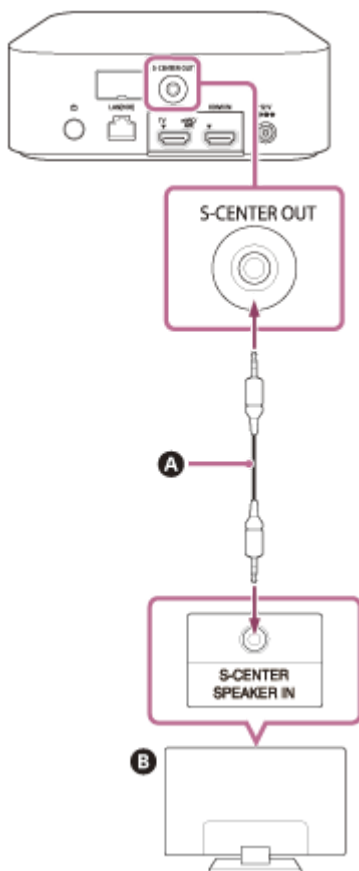

- A TV center speaker mode cable (supplied)
- B TV

Note

- Check that the connectors are firmly inserted.

Hint

- If the TV center speaker mode cable is not long enough, use a commercially available stereo mini cable.

To output sound from the TV

Access [Settings] - [Sound Settings] and enable [Acoustic Center Sync] on the remote control screen on the app.

Depending on the input, audio signal, or sound field settings, sound may not be output from the TV. For details, refer to the table below.

○ : Sound is output from both the speaker system and TV.

–: No sound is output from the TV. Sound is output from the speaker system only.

Setting	TV, HDMI input: 2-channel content	TV, HDMI input: Multi-channel content	BLUETOOTH input, music service, AirPlay
[Sound field](*) : On and [Sound Field Setting](**): [360 Spatial Sound Mapping]	○	○	–
[Sound field](*) : On and [Sound Field Setting](**): [Dolby Speaker Virtualizer], [DTS Neural:X]	–	–	–
[Sound field](*) : Off	–	○	–

* Displayed on the remote control screen on the app.

** Displayed by tapping [Settings] - [Sound Settings] - [Sound Field Setting] on the remote control screen on the app.

Related Topic

- [Connecting to a TV](#)
- [Adjusting Sound Quality](#)
- [\[Sound Settings\]](#)

TP1001174827

Connecting an AV Device

8K video and high-quality audio such as Dolby Atmos, Dolby TrueHD, DTS:X, etc. can be played by connecting an AV device (Blu-ray Disc player, set-top box, cable box, satellite box, gaming console, etc.) in the following way.

- 1 Connect the HDMI OUT jack on the AV device and HDMI IN jack on the TV using an HDMI cable (not supplied).
- 2 Connect the speaker system and TV using the HDMI cable (supplied).

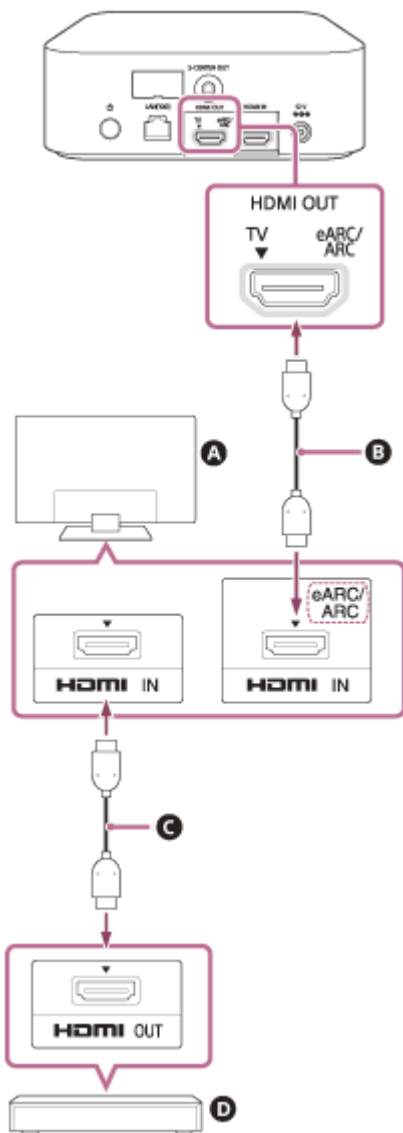

- A TV
- B HDMI cable (supplied)
- C HDMI cable (not supplied)
- D AV device (Blu-ray Disc player, set-top box, cable box, satellite box, gaming console, etc.)

The AV device can be connected to the speaker system directly

To play 360 Reality Audio content on an AV device, connect the AV device directly to the speaker system. By connecting an AV device directly to the speaker system, higher quality audio formats such as Dolby Atmos that are played on the AV device can also be output from the speaker system, even if the TV is not compatible with eARC.

1. Connect the speaker system and TV using the HDMI cable (supplied).
2. Remove the sticker from the HDMI IN jack on the speaker system.
3. Connect the HDMI IN jack on the speaker system and HDMI OUT jack on the AV device using an HDMI cable (not supplied).

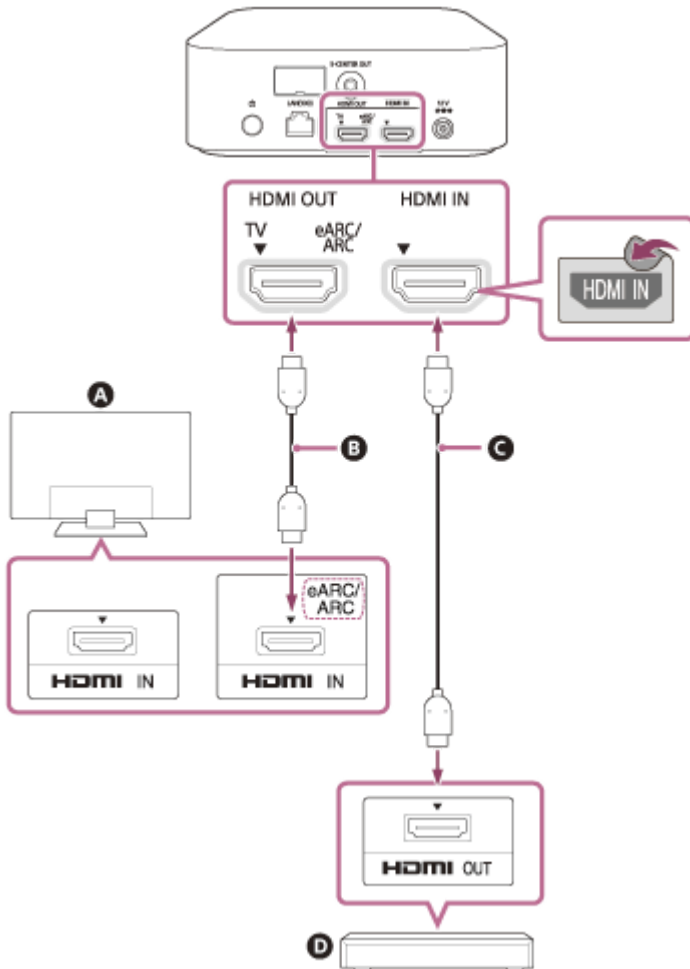

- A** TV
- B** HDMI cable (supplied)
- C** HDMI cable (not supplied)
- D** AV device (Blu-ray Disc player, set-top box, cable box, satellite box, gaming console, etc.)

Note

- Check that the connectors are firmly inserted.
- To view 8K content, the TV and HDMI cable need to be compatible with 8K. For details, refer to the operating instructions of the TV.
- Some TV controls may become limited. For instance, system sounds and voice response may not be output. Refer to the operating instructions of your TV.
- The types and number of devices that can be controlled by the Control for HDMI function are limited by the HDMI CEC standard as follows.
 - Recording devices (Blu-ray Disc recorder, DVD recorder, etc.): Up to 3 devices
 - Playback devices (Blu-ray Disc player, DVD player, etc.): Up to 3 devices
 - Tuner-related devices: Up to 4 devices
 - Audio system (receiver/headphones): Up to 1 device (used by this speaker system)

Hint

- Use an HDMI cable that is compatible with the video format of the device being connected, and select the HDMI signal format by accessing [Settings] - [HDMI Settings] - [HDMI Signal Format] on the remote control screen on the app.
- For the supported audio formats, refer to “Related Topic.”

Related Topic

- [Connecting to a TV](#)
- [Playing 360 Reality Audio Content from the Connected AV Device](#)
- [Supported Audio Formats](#)
- [Supported HDMI Video Formats](#)

TP1001174828

5-049-832-11(4) Copyright 2024 Sony Corporation

Connecting to an AC Outlet (Mains)

- 1 Connect the AC adaptor (supplied) and AC power cord (mains lead) (supplied)(*) to the DC IN terminal on the control box, then connect them to an AC outlet (mains).

* Except for North American models

For North American models

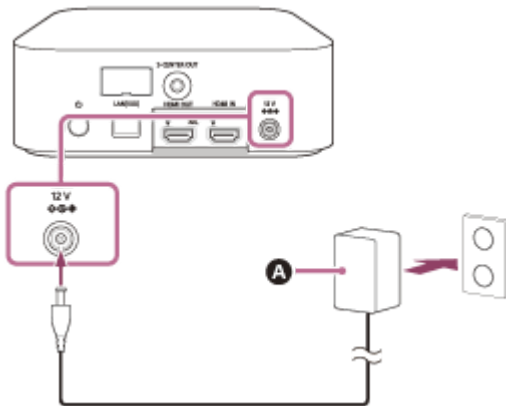

For other models

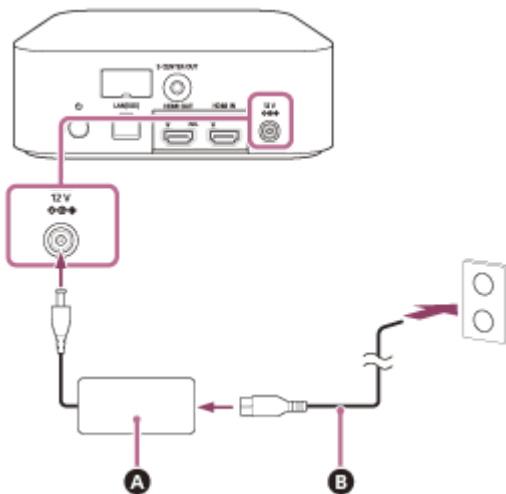

- A** AC adaptor (supplied)
- B** AC power cord (mains lead) (supplied)

- 2 Connect the AC power cords (mains leads) for the speakers (supplied) to the AC inlets on the 4 speakers, then connect the AC power cords (mains leads) to AC outlets (mains).

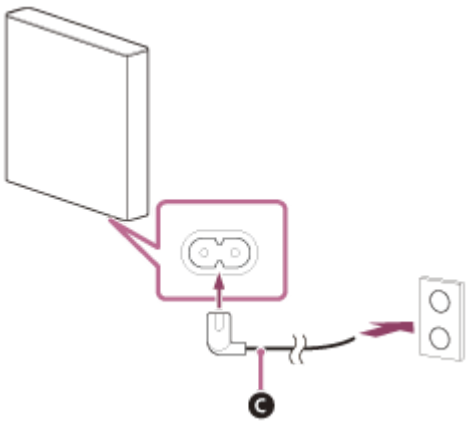

C AC power cord (mains lead) for the speaker (supplied)

When the AC power cord (mains lead) for the speaker is connected to an AC outlet (mains), the speaker turns on and the power indicator on the speaker flashes in green.

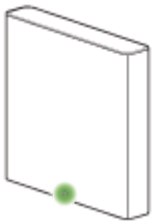

TP1001053974

Performing Initial Setup with the “Sony | BRAVIA Connect” App

To set up the speaker system, use the “Sony | BRAVIA Connect” app.

- 1 Check that the control box and TV are connected and that the control box and speakers are connected to a power source.
- 2 Download and install the “Sony | BRAVIA Connect” app on your smartphone.



- 3 Open the app and follow the instructions on the screen to complete the setup.

After the control box is turned on, it is automatically connected to the speakers and the power indicators on the speakers light up in green.

If the speaker is not connected to the control box, the power indicator on the speaker lights up in red. Refer to “[If the Speakers Are Not Connected Correctly](#)” for how to connect the speaker to the control box.

Related Topic

- [Connecting to a TV](#)
- [If Your TV Has the S-CENTER SPEAKER IN Jack](#)
- [Connecting an AV Device](#)
- [Connecting to an AC Outlet \(Mains\)](#)

TP1001053973

Home Theatre System
BRAVIA Theatre Quad

If the Speakers Are Not Connected Correctly

If the speaker is not connected to the control box, the power indicator on the speaker lights up in red and the instructions for connecting the speaker appear on the app screen. Connect the speaker to the control box by following these instructions on the app.

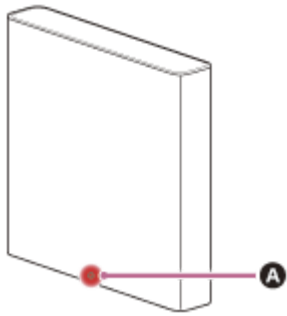

A Power indicator

Hint

- Check the speaker connection status in [Settings] - [Wireless Speaker Settings] on the remote control screen on the app.

Related Topic

- [Performing Initial Setup with the “Sony | BRAVIA Connect” App](#)
- [\[Easy Initial Setup\]](#)
- [\[Wireless Speaker Settings\]](#)

TP1001174829

Listening to TV Sound

Operate the remote control screen on the app as follows.

- 1 Tap the playback information/input switching area on the upper part of the screen to switch the input to [TV].

If the remote control screen on the app that can operate the speaker system and BRAVIA is displayed, there is no need to operate the input switching of the speaker system. The audio input on the speaker system switches in conjunction with the content being viewed on the TV.

- 2 Adjust the volume.

To operate using the supplied remote control

1. Press INPUT (Input) to display [TV] in the front panel display on the control box.
2. Adjust the volume.

Note

- If there is no picture when TV (eARC/ARC) input is selected, select the preferred TV channel by using the TV remote control.
- Depending on whether you turn on the TV or the speaker system first, the speaker system may be muted and cause [MUTING] to appear in the front panel display on the control box. In this case, turn on the TV before turning on the speaker system.

TP1001054252

Playing the Connected AV Device

Operate the remote control screen on the app as follows.

- 1 Tap the playback information/input switching area on the upper part of the screen to switch the input to [HDMI].

If the remote control screen on the app that can operate the speaker system and BRAVIA is displayed, there is no need to operate the input switching of the speaker system. The audio input on the speaker system switches in conjunction with the content being viewed on the TV.

- 2 Adjust the volume.

To operate using the supplied remote control

1. Press INPUT (Input) to display [HDMI] in the front panel display on the control box.
2. Adjust the volume.

Note

- If there is no picture from the device connected to the HDMI IN jack on the speaker system, press the playback button on the connected device.
- When there is no picture from the connected device or the picture from the connected device is not output correctly, access [Settings] - [HDMI Settings] and change the [HDMI Signal Format] settings on the remote control screen on the app.
- Check that the speaker system is connected to a device that is HDCP (High-bandwidth Digital Content Protection) compliant. For details, refer to the operating instructions supplied with the connected device.
- If HDR content cannot be shown in high dynamic range, check that the settings of the TV or device connected to the speaker system. For details, refer to the operating instructions supplied with the TV or connected device.
- Depending on the [HDMI Signal Format] setting, an AV device may not be able to output HDR content in the HDR format. Access [Settings] - [HDMI Settings] and change the [HDMI Signal Format] settings on the remote control screen on the app to accommodate the video format that is supported by the AV device.
- If the picture and sound of the device that is connected to the speaker system are not output from the TV while the speaker system is turned off, access [Settings] - [HDMI Settings] - [Signal Pass Through] and set this to [Auto] or [On] on the remote control screen on the app.

Related Topic

- [\[HDMI Settings\]](#)

TP1001174830

Home Theatre System
BRAVIA Theatre Quad

Adjusting Sound Quality

The following sound quality adjustments can be performed on the remote control screen on the app or on the supplied remote control.

Operating using the remote control screen on the app

When an app-compatible BRAVIA is connected to the speaker system using an HDMI cable, select [Picture & Sound].

- **[Sound field]**
Outputs sound with the surround sound effect. This setting can be used to experience surround sound with a sense of presence.
- **[Voice mode]**
Emphasizes dialog and makes it easier to hear.
- **[Voice Zoom]**
This function is enabled when a Sony TV compatible with the linkage function of the speaker system is connected. When TV input is selected on the speaker system, the voice zoom works instead of the voice mode. The voice zoom can adjust only the volume of the human voice without changing the overall volume. The voice volume of the newscaster can be adjusted to be louder to make it easier to hear, and the voice volume can be adjusted to be quieter for live sports broadcasts or other situations where the commentary or play-by-play commentary is too loud.
- **[Night mode]**
Outputs clear sound even at a low volume for late night use and features clear dialog and minimum loss of fidelity.

Operating using the supplied remote control

Each time you press a button on the supplied remote control, the setting changes and the setting appears in the front panel display on the control box.

- **SOUND FIELD (Sound field)**
Outputs sound with the surround sound effect. This setting can be used to experience surround sound with a sense of presence.
[SF.ON]: The sound field is set to on.
[SF.OFF]: The sound field is set to off.
- **VOICE (Voice mode)**
Emphasizes dialog and makes it easier to hear.
The voice zoom works to adjust the volume of human voices when a TV compatible with the linkage function of the speaker system is connected. When voice zoom is turned on, the last adjusted value in the TV menu or remote control screen on the app will be applied.
[Vo.ON]: The voice mode is set to on.
[Vo.OFF]: The voice mode is set to off.
- **NIGHT (Night mode)**
Outputs clear sound even at a low volume for late night use and features clear dialog and minimum loss of fidelity.
[N.ON]: The night mode is set to on.
[N.OFF]: The night mode is set to off.

Note

- The sound field is not available during test tone output.
- If [Sound Field Setting] is set to [Dolby Speaker Virtualizer] and the sound field is set to on, the voice mode is disabled. (*)
- Depending on the combination of the sound field setting(*) and content, the [Sound Field Optimization](**) effect may not be applied.
- The sense of presence that can be achieved by the surround sound processing may vary depending on the playback content.
- When playing multi-channel audio, check the digital audio output setting on the device that is connected to the speaker system. For details, refer to the operating instructions supplied with the connected device.
- Some speakers may not output sound depending on the content or sound field setting(*).
- The night mode automatically turns off when the speaker system is turned off.
- Check the URL below for TVs that are compatible with the linkage function of the speaker system.
https://www.sony.net/hav_faq
- Depending on the TV setting or content, the voice zoom may not work.

* On/off setting of the sound field and the setting displayed after you tap [Settings] - [Sound Settings] - [Sound Field Setting] on the remote control screen on the app.

** Displayed when you tap [Settings] - [Sound Settings] - [Sound Field Optimization] on the remote control screen on the app.

Related Topic

- [\[Sound Settings\]](#)

TP1001054316

Home Theatre System
BRAVIA Theatre Quad

Listening to Music by Pairing the BLUETOOTH Device that is Connected for the First Time

To use the BLUETOOTH function, the speaker system and BLUETOOTH device need to be paired in advance. Pairing is the process of registering devices with each other in advance.

1 Turn on the BLUETOOTH device.

2 Switch the input to [Bluetooth] on the remote control screen on the app.

If another BLUETOOTH device is already connected to the speaker system, select [Connect to other devices]. The speaker system enters the pairing mode and [PAIRING] appears in the front panel display on the control box by switching to the [Bluetooth] input.

3 Look for the speaker system on the BLUETOOTH device by performing the pairing operation.

The list of the BLUETOOTH devices detected by the BLUETOOTH device appears on the screen of the BLUETOOTH device.

For how to perform pairing with the BLUETOOTH device, refer to the operating instructions of the BLUETOOTH device.

4 Select the speaker system(*) from the list of devices that is displayed on the screen of the BLUETOOTH device and register the speaker system and BLUETOOTH device with each other.

If a passkey is requested, enter "0000."

* BRAVIA Theatre Quad or the device name that is set in [Unit Name].

5 Confirm on the remote control screen on the app that the speaker system and the BLUETOOTH device are connected via the BLUETOOTH function.

The name of the connected BLUETOOTH device appears in the front panel display on the control box.

6 Start audio playback with the music app on the connected BLUETOOTH device.

Sound is output from the speaker system.

7 Adjust the volume.

Adjust the speaker system volume using the remote control screen on the app, music playback app, or (Volume) +/- on the supplied remote control.

Play or pause content by tapping the playback operation icon on the remote control screen on the app.



Note

- If pairing fails, try performing the following on the BLUETOOTH device.
 - Accept pairing request.
 - If the maximum number of paired devices on the BLUETOOTH device has been reached, remove any unneeded devices.

- If the speaker system has been reset, delete the pairing information for the speaker system from the BLUETOOTH device and perform pairing again.

Hint

- If there is no BLUETOOTH device paired (when using the speaker system immediately after purchase, etc.), the speaker system enters the pairing mode when the input is simply changed to [Bluetooth].
- Perform pairing for a second or subsequent BLUETOOTH device.

Related Topic

- [Setting the Wireless Function to On or Off](#)
- [Resetting the Speaker System](#)

TP1001054655

Listening to Music from the Paired BLUETOOTH Device

1 Turn on the BLUETOOTH function on the BLUETOOTH device.

2 Switch the input to [Bluetooth] on the remote control screen on the app.

The speaker system automatically reconnects to the BLUETOOTH device that was most recently connected to the speaker system.

If another BLUETOOTH device is already connected to the speaker system, select [Connect to other devices].

Then, use the BLUETOOTH device that you want to connect to the speaker system to select the speaker system as the device being connected to for the BLUETOOTH function.

3 Start audio playback with the music app on the connected BLUETOOTH device.

Sound is output from the speaker system.

4 Adjust the volume.

Adjust the speaker system volume from the remote control screen on the app or music playback app.

Play or pause the content by tapping the playback operation icon on the remote control screen on the app.

To operate using the supplied remote control

1. Turn on the BLUETOOTH function on the BLUETOOTH device.
2. Press INPUT to select the BLUETOOTH input.

The speaker system automatically reconnects to the BLUETOOTH device that was most recently connected to the speaker system.

If you cannot connect to the BLUETOOTH device that you used in step 1, select [Connect to other devices] on the remote control screen on the app. Then, use the BLUETOOTH device that you used in step 1 to select the speaker system as the device being connected to for the BLUETOOTH function.

3. Start audio playback with the music app on the connected BLUETOOTH device.
4. Adjust the volume.

Hint

- If a BLUETOOTH connection is not established between the speaker system and BLUETOOTH device, select the speaker system on the BLUETOOTH device.
- If sound delay occurs, it may be improved by accessing [Settings] - [Bluetooth Settings] - [Bluetooth Connection Quality] and set this to [Priority on Stable Connection] on the remote control screen on the app.

To disconnect the BLUETOOTH device

Use one of the following methods to disconnect.

- Turn off the BLUETOOTH function on the BLUETOOTH device.
- Turn off the speaker system or BLUETOOTH device.

Related Topic





- [Setting the Wireless Function to On or Off](#)

TP1001054654

5-049-832-11(4) Copyright 2024 Sony Corporation

Setting the Wireless Function to On or Off

The wireless function is set to on by default.

- Press INPUT (Input),  (Volume) –, and  (Muting) on the supplied remote control in this order to turn off the BLUETOOTH and Wireless LAN function. [RFOFF] appears in the front panel display on the control box.
- Press INPUT (Input),  (Volume) –, and  (Muting) on the supplied remote control in this order again to turn on the BLUETOOTH and Wireless LAN function. [RF ON] appears in the front panel display on the control box.

Note

- The following operations cannot be performed when the wireless function is set to off:
 - Pairing and/or connecting with a BLUETOOTH device.
 - Using “Sony | BRAVIA Connect.”
 - Playing music on the network via wireless LAN.
- If the wireless function is set to off, [Network/Bluetooth Standby] is automatically set to off. (European models only)

TP1001054652

Home Theatre System
BRAVIA Theatre Quad

About 360 Reality Audio

The speaker system is compatible with 360 Reality Audio.

360 Reality Audio is a new music experience that uses Sony's object-based spatial acoustic technology to create a highly realistic sound field that makes you feel as if you have entered the space where an artist is performing live.

For details, refer to the following URL.

<https://www.sony.net/360RA/>

Related Topic

- [Playing 360 Reality Audio Content from the Connected AV Device](#)

TP1001273838

Playing 360 Reality Audio Content from the Connected AV Device

360 Reality Audio content can be played on the speaker system by connecting an AV device that is compatible with 360 Reality Audio to the speaker system.

- 1 Connect an AV device that is compatible with 360 Reality Audio to the HDMI IN jack on the speaker system.
- 2 Tap the playback information/input switching area on the upper part of the remote control screen on the app to switch the input to [HDMI].
- 3 Play 360 Reality Audio compatible content by operating the connected AV device.

To operate using the supplied remote control

1. Connect an AV device that is compatible with 360 Reality Audio to the HDMI IN jack on the speaker system.
2. Press INPUT (Input) to display [HDMI] in the front panel display on the control box.
3. Play 360 Reality Audio compatible content by operating the connected AV device.

Hint

- For details about AV devices that are compatible with 360 Reality Audio, refer to the following URL.
<https://www.sony.net/360RA/#speakers>

Related Topic

- [Connecting an AV Device](#)

TP1001273837

Home Theatre System
BRAVIA Theatre Quad

Using Spotify

Select music on the Spotify app and play it on the speaker system.

Playing music on the speaker system by using the “Spotify Connect” function

Use your phone, tablet or computer as a remote control for Spotify. Go to spotify.com/connect to learn how.

Hint

- If [Settings] - [System Settings] - [Network/Bluetooth Standby] is set to [Off] on the remote control screen on the app, playback cannot be started while the speaker system is in standby mode. If set to [On], the speaker system starts up from standby mode and plays music.

Resuming music that was being played on a mobile device

1 Press INPUT (Input) to display [SPOTIFY] in the front panel display on the control box.

If you were playing music on Spotify with the speaker system, the music that was being played on Spotify is resumed.

Note

- The Spotify app may not be available in some countries/regions.

TP1001174832

Home Theatre System
BRAVIA Theatre Quad

Using AirPlay

The speaker system is compatible with AirPlay. Music content can be selected on an iOS device such as an iPhone, iPad, or iPod touch and stream it to the speaker system.

- 1 **Connect the iOS device via Wi-Fi to the same network as that of the speaker system.**
- 2 **Play the music that you want to stream on the iOS device.**
- 3 **Display the AirPlay icon () on the iOS device and tap it.**
- 4 **Select the speaker system as the speaker to stream to on the iOS device.**

The music is played on the speaker system.

Hint

- Music can be streamed to multiple speakers by selecting other speakers together with the speaker system.
- If [Settings] - [System Settings] - [Network/Bluetooth Standby] is set to [Off] on the remote control screen on the app, playback cannot be started while the speaker system is in standby mode. If set to [On], the speaker system starts up from standby mode and plays music.

Streaming music on the speaker system by talking to Siri

If you add the speaker system to the Home app on the iOS device, you can stream music to the speaker system by talking to Siri.

Note

- Because the speaker system does not have a microphone, you cannot talk to the speaker system to operate it.
- Not all Siri features are available on the speaker system.

TP1001174833

Operating the Speaker System by Interlocking with a TV (Control for HDMI Function)

Speaker system controls such as power on/off or volume adjustment can be interlocked with a TV's controls by using an HDMI cable to connect the speaker system with a TV that is compatible with the Control for HDMI function.

About the Control for HDMI function

The Control for HDMI function is a function that interlocks devices that are connected using an HDMI (High-Definition Multimedia Interface) cable so that these devices can be operated together.

Although this function is supported by devices that are compatible with the Control for HDMI function, it may not work if devices other than those manufactured by Sony are connected.

Preparing to operate the speaker system by interlocking it with a TV

Enable the Control for HDMI function settings on the TV that is connected to the speaker system using an HDMI cable. The Control for HDMI function setting on the speaker system is enabled by default.

Note

- The TV needs to be compatible with the Control for HDMI function. For details, refer to the operating instructions of the TV.
- Check the speaker settings on the TV. The speaker system power becomes synced with the speaker settings on the TV. For details, refer to the operating instructions of the TV.
- Depending on the TV, if sound was previously output from the speakers on the TV, the speaker system may not turn on through interlocking with the TV power controls even when the TV is turned on.

Hint

- If a device such as a Blu-ray Disc player is connected to a TV using an HDMI cable, enable the Control for HDMI function on the device.
- For how to enable the Control for HDMI function on a TV or Blu-ray Disc player, refer to its operating instructions.
- If the Control for HDMI ("BRAVIA Sync") function is enabled on a TV manufactured by Sony, the Control for HDMI function on the speaker system is also automatically enabled.
- The Control for HDMI function setting on the speaker system can be changed by accessing [Settings] - [HDMI Settings] - [Control for HDMI] on the remote control screen on the app.

Performing power operation or volume adjustment by a TV remote control

When the TV is turned on/off or the volume is adjusted with the TV remote control, the speaker system power operation or volume adjustment is interlocked.

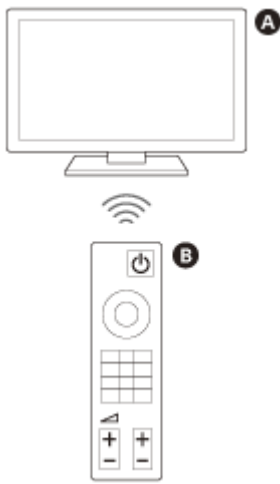

- A** TV
- B** TV remote control

Power interlocking

When the TV is turned on, the speaker system turns on automatically. When the TV is turned off, the speaker system turns off automatically.

Note

- If the speaker system is turned off before the TV is turned off, the speaker system may not turn on automatically even when the TV is turned on next. If this occurs, perform the following operation.
 - Select the speaker system as the sound output device in the TV menu.
 - If a Sony TV is being used, turn on the speaker system while the TV is turned on.

Volume adjustment

The sound of the TV that you are watching is output from the speaker system automatically. The speaker system volume can be adjusted with the TV remote control.

One-touch play function

The speaker system and TV automatically turn on when content is played on a Blu-ray Disc player connected to the speaker system or when an operation such as the pressing of the PS button on a PlayStation®5 controller is performed.

Note

- Depending on the TV, if [Settings] - [HDMI Settings] - [Signal Pass Through] is set to [Auto] or [On] on the remote control screen on the app and the TV sound was last output from the speakers on the TV, the speaker system may not turn on and sound and picture may be output on the TV only even if device content is played.

Related Topic

- [\[HDMI Settings\]](#)

TP1001054651

Home Theatre System
BRAVIA Theatre Quad

Operating the Speaker System by Interlocking with a TV Compatible with the “BRAVIA Sync” Function

“BRAVIA Sync” is an extended function that is developed by Sony based on the Control for HDMI function. By using an HDMI cable to connect “BRAVIA Sync”-compatible devices such as a TV or a Blu-ray Disc player, the devices can be interlocked with each other and controlled.

To use “BRAVIA Sync”

Enable the Control for HDMI function on the Sony device to enable “BRAVIA Sync.”

What you can do with “BRAVIA Sync”

Control for HDMI function

- Power interlocking
- Volume adjustment
- One-touch play function

Related Topic

- [Operating the Speaker System by Interlocking with a TV \(Control for HDMI Function\)](#)
- [\[HDMI Settings\]](#)

TP1001054650

Home Theatre System
BRAVIA Theatre Quad

[Wireless Speaker Settings]

These are the settings for the connection of the supplied speakers or the optional subwoofer. The following setting items appear by tapping [Settings] - [Wireless Speaker Settings] on the remote control screen on the app.

Wireless speaker status check

Used to check the connection status of the speakers connected to the speaker system on the app screen.

[Wireless Speaker Connection]

Used to configure the connection settings for an optional subwoofer. This can also be used to replace a connected subwoofer with a new subwoofer.

[Wireless Channel]

Normally set to [Auto] (the best channel for wireless communication is automatically selected). If sound dropping occurs, this may be improved by fixing the channel.

[Wireless Playback Quality]

Used to set the wireless playback quality for the 4 supplied speakers and optional subwoofer.

TP1001054644

Home Theatre System
BRAVIA Theatre Quad

[Sound Settings]

These are the settings for audio output.

The following setting items appear by tapping [Settings] - [Sound Settings] on the remote control screen on the app.

[Sound Field Optimization]

Optimizes the sound field effect. Follow the instructions on the screen.

[Sound Field Setting]

Used to select the type of surround sound effect. To enjoy the effect of the selected sound field, turn on the sound field function on the supplied remote control or the remote control screen on the app.

[Height of Sound Field]

Adjusts the height of the entire sound field to improve the sense of unity between picture and sound.

[Acoustic Center Sync]

Outputs the center speaker portion of the speaker system sound from the TV by connecting the speaker system and TV using the supplied HDMI cable and the supplied TV center speaker mode cable. Set [Control for HDMI] to [On].

[Sound output check]

Used to check the sound output of the current settings and see whether sound is being output consistently from each speaker.

[DSEE Ultimate]

Plays compressed music accurately upscaled with AI technology.

[Audio DRC]

Compresses the dynamic range (range between the loudest and quietest parts) of the audio signal to make it easier to hear softer sounds.

[DTS Dialog Control]

The volume of dialog is adjusted while content that is compatible with the DTS:X dialog control function is being played.

[A/V Sync]

Adjusts the delay between the picture and sound.

[Automatically adjust volume]

Reduces volume changes caused by the input signal. This function is effective when the volume of a TV commercial is louder than that of the TV program.

[IMAX Enhanced Mode]

Automatically adjust sound to match the creator's intent when playing IMAX Enhanced content.

The optional speakers are required to enjoy IMAX® Enhanced. For details, refer to the following URL.

<https://www.sony.net/comp-home/>

Related Topic

- [Supplied Remote Control](#)
- [Remote Control Screen on the App](#)
- [If Your TV Has the S-CENTER SPEAKER IN Jack](#)
- [\[HDMI Settings\]](#)

TP1001054648

5-049-832-11(4) Copyright 2024 Sony Corporation

Home Theatre System
BRAVIA Theatre Quad

[HDMI Settings]

These are the settings for HDMI.

The following setting items appear by tapping [Settings] - [HDMI Settings] on the remote control screen on the app.

[Control for HDMI]

When the Control for HDMI function is enabled, devices that are connected using an HDMI cable are operated with each other and receive ARC audio from the TV.

[TV Power Off Link]

When the TV is turned off, the speaker system is also turned off by interlocking with the TV power. Set [Control for HDMI] to [On].

[Signal Pass Through]

Sends the HDMI signal to the TV even when the speaker system is turned off.

[eARC]

When a TV that is compatible with eARC is connected, enable this setting to enable the eARC function. When a TV that is compatible with ARC (but not compatible with eARC) is connected, the ARC function works regardless of how this function is set.

When eARC is enabled, check the eARC setting on the TV. For details, refer to the operating instructions of the TV.

[HDMI Signal Format]

Used to set the video format that can be received. If the picture and sound from a device that is connected to the speaker system are not being output correctly, change this setting.

Note

- If the video format selected for this setting is not output, the video signal specifications and settings of your TV may not match those of the speaker system. Check the video input specifications and settings of your TV. For TV specifications and settings, refer to the operating instructions of your TV.
- If the picture and sound are not output when [Enhanced format (4K120, 8K)] is set, set to [Enhanced format] or [Standard format].
- If the picture and sound are not output when [Enhanced format] is set, set to [Standard format].
- For details on the video formats that can be received and the type of HDMI cable that can be used, refer to "[Supported HDMI Video Formats](#)."
- The VRR/ALLM/SBTM function is linked to this setting and enabled when [Enhanced format (4K120, 8K)] (the default setting) is set.

[Video output for PIP/PBP-displayed TV]

Outputs the picture from the HDMI input on the speaker system to the TV when TV input is selected on the speaker system. Turn this setting on when you want to display two windows on a TV, including the picture from the HDMI input on the speaker system.

TP1001054647

5-049-832-11(4) Copyright 2024 Sony Corporation

Home Theatre System
BRAVIA Theatre Quad

[Bluetooth Settings]

This is the advanced setting for the BLUETOOTH function.

The following setting item appears by tapping [Settings] - [Bluetooth Settings] on the remote control screen on the app.

[Bluetooth Connection Quality]

Used to set the BLUETOOTH connection quality when playing audio from a mobile device on the speaker system.

Related Topic

- [Setting the Wireless Function to On or Off](#)

TP1001054646

Home Theatre System
BRAVIA Theatre Quad

[System Settings]

These are the settings for the speaker system.

The following setting items appear by tapping [Settings] - [System Settings] on the remote control screen on the app.

[Auto Standby]

When the speaker system is not being operated and there is no signal input for about 20 minutes, the speaker system automatically enters the network standby mode or standby mode.

[Network/Bluetooth Standby]

The speaker system can be turned on via the network or BLUETOOTH function. The speaker system can also be turned on from the app.

On: After activating the [Auto Standby] function, the speaker system enters the network standby mode.

Off: After activating the [Auto Standby] function, the speaker system enters the standby mode.

Note

- When [Network/Bluetooth Standby] is set to [Off], it may take longer for audio to be output from the speaker system when the speaker system is turned on.

[Auto Update]

Used to set whether network updates are performed automatically.

[Dimmer]

Used to adjust the brightness of the front panel display and indicators. The brightness of the indicators for an optional subwoofer can also be adjusted.

[Unit Name]

Used to change the name of the speaker system that is displayed when a function such as the BLUETOOTH function is being used.

[System Information]

Displays speaker system information such as the software version.

[Software License Information]

Displays the software license information.

Home Theatre System
BRAVIA Theatre Quad

[Network Settings]

These are the settings for the network.

The following setting items appear by tapping [Settings] - [Network Settings] on the remote control screen on the app.

[Network Connect Status]

Used to check the network settings on the speaker system.

[Account Management]

Used to check the list of users currently using the speaker system or used to cancel user registration. Up to 20 user accounts can be registered.

[External Control]

Used to enable or disable the control of the speaker system from an external control device. This setting item is for custom installers only. Normally, disable this setting item.

[Privacy Setting]

The speaker system collects information on your device usage. Check the privacy policy that is displayed during setup, and set your approval or disapproval for the data collection.

Hint

- Once you have given your approval, you can stop the collection of information by withdrawing your consent or resetting the speaker system to its original settings.

Related Topic

- [Resetting the Speaker System](#)

TP1001174834

Home Theatre System
BRAVIA Theatre Quad

[Easy Initial Setup]

The basic settings, speaker settings, and surround sound optimization for the speaker system can be easily performed. Tap [Settings] - [Easy Initial Setup] on the remote control screen on the app.

TP1001054649

5-049-832-11(4) Copyright 2024 Sony Corporation

Home Theatre System
BRAVIA Theatre Quad

[Software update]

Used to update the software of the control box, 4 supplied speakers, or optional subwoofer.
Tap [Settings] - [Software update] on the remote control screen on the app.

TP1001174835

5-049-832-11(4) Copyright 2024 Sony Corporation

Saving Power in Standby Mode

To reduce power consumption in standby mode, configure the settings as follows.

- Access [Settings] - [HDMI Settings] - [Signal Pass Through] and set this to [Off] on the remote control screen on the app.
- Access [Settings] - [System Settings] - [Network/Bluetooth Standby] and set this to [Off] on the remote control screen on the app.

Note

- When [Network/Bluetooth Standby] is set to [Off], it may take longer for audio to be output from the speakers.

TP1001174836

Troubleshooting

If you have any problems, please follow the process below.

1. Check that the other devices connected to the speaker system and TV are connected to the correct jacks with the correct cables, and that they are firmly inserted all the way to the back.



2. Check that the ventilation holes of the speaker system are not blocked.



3. Disconnect the AC adaptor(*) and AC power cords (mains leads) from the wall outlet (mains) to turn off, and then wait several minutes before reconnecting them.

* North American models only



4. Access the Sony support site from the menu of the “Sony | BRAVIA Connect” app to look up the cause and solution of the issue, or check the support website below.

<https://www.sony.net/support/HT-A9M2/>



5. Reset the speaker system.

All the speaker system settings are returned to their initial state.



6. If the speaker system still does not work properly, consult your nearest Sony dealer.

Related Topic

- [Resetting the Speaker System](#)

Home Theatre System
BRAVIA Theatre Quad

Resetting the Speaker System

If the speaker system still does not operate properly with “[Troubleshooting](#),” reset the speaker system.

Resetting the control box

Press and hold  (power) on the control box for more than 10 seconds.



Resetting the speakers

Press and hold **LINK** on the bottom of the speaker for more than 10 seconds.

The power indicator on the speaker flashes slowly in red and the reset starts. The power indicator on the speaker flashes in green and amber alternately when the reset is completed.

After the reset is completed, disconnect the AC power cord (mains lead) for the speaker from the AC outlet (mains), then reconnect the AC power cord (mains lead) for the speaker after the power indicator on the speaker turns off.

Note

- When the speaker system is reset, delete the pairing information for the speaker system (name of the speaker system (**), LE_name of the speaker system) from the BLUETOOTH setting on the smartphone(*), etc. connected to the speaker system.
 - * Smartphones with the app installed, audio devices compatible with BLUETOOTH, etc.
 - ** BRAVIA Theatre Quad or the device name that is set in [Unit Name].
- If you reset the control box or speakers, perform the initial setup on the app.
- When [External Control] is enabled, this reset operation alone will not delete some of the setting information. Perform the following procedure before resetting.
Procedure: Press and hold down NIGHT (Night mode) on the supplied remote control for 5 seconds, then press  (Volume) +,  (Volume) -, and  (Muting) in this order.

Related Topic

- [Performing Initial Setup with the “Sony | BRAVIA Connect” App](#)
- [\[Wireless Speaker Settings\]](#)

TP1001054642

Home Theatre System
BRAVIA Theatre Quad

Specifications

Speakers (YY2080C2/YY2080C3/YY2080C4/YY2080C5)

The following descriptions are the specifications per speaker.

Front speaker section

Woofers

85 mm × 85 mm (3 3/8 in × 3 3/8 in) Cone type

Midrange speaker

60 mm (2 3/8 in) Cone type

Tweeter

19 mm (3/4 in) Soft dome type

Speaker system

3way speaker system bass reflex type

Top speaker section

Speaker

36 mm × 79 mm (1 7/16 in × 3 1/8 in) Cone type

Speaker system

Full range speaker system acoustic suspension type

General

Power consumption

On: 20 W

Network standby mode (power indicator is lit in red): 1.1 W or less

Turned off (power indicator is off): 0.5 W or less*

* When you press and hold the LINK for 2 seconds or more and then release your finger, the speaker shifts to the power off mode and the power indicator is turned off. Press the LINK to use the speaker again.

When the [Auto Standby] function is enabled, if the speaker system is not being operated and there is no signal input for about 20 minutes, the speakers automatically enter the network standby mode.

Disabling the [Auto Standby] function will increase the power consumption of this speaker system.

Dimensions* (approx.) (w/h/d)

Speaker:

289 mm × 275 mm × 55 mm (11 1/2 in × 10 7/8 in × 2 1/4 in)

Speaker with the table stand:

289 mm × 306 mm × 129 mm (11 1/2 in × 12 1/8 in × 5 1/8 in)

Speaker with the wall mounting bracket:

289 mm × 279 mm × 73 mm (11 1/2 in × 11 in × 2 7/8 in)

* Not including projection portion

Mass (approx.)

Speaker:

2.4 kg (5 lb 5 oz)

Speaker with the table stand:

2.6 kg (5 lb 12 oz)

Speaker with the wall mounting bracket:

2.7 kg (5 lb 16 oz)

Control Box (YY2080C1)

HDMI section

Connector

Type A (19pin)

LAN section

LAN(100) terminal

100BASE-TX Terminal

Wireless LAN section

Communication system

IEEE 802.11 a/b/g/n/ac

Frequency band

2.4 GHz, 5 GHz

BLUETOOTH section

Communication system

BLUETOOTH Specification version 5.2

Output

BLUETOOTH Specification Power Class 2

Maximum communication range

Line of sight approx. 30 m (98.4 ft) ¹⁾

Maximum number of devices to be registered

9 devices: BLUETOOTH Low Energy (Connection with Sony | BRAVIA Connect)

9 devices: BLUETOOTH Classic (A2DP)

Frequency band

2.4 GHz band (2.400 0 GHz - 2.483 5 GHz)

Modulation method

FHSS (Freq Hopping Spread Spectrum)

Compatible BLUETOOTH profiles²⁾

A2DP (Advanced Audio Distribution Profile)

AVRCP (Audio Video Remote Control Profile)

Supported Codecs³⁾

SBC (Subband Codec)

AAC (Advanced Audio Coding)

LDAC™⁴⁾

Transmission range (A2DP)

20 Hz - 40 000 Hz (LDAC sampling frequency 96 kHz with 990 kbps transmission)

20 Hz - 20 000 Hz (Sampling frequency 44.1 kHz)

1) The actual range will vary depending on factors such as obstacles between devices, magnetic fields around a microwave oven, static electricity, cordless phone use, reception sensitivity, the operating system, software applications, etc.

2) BLUETOOTH standard profiles indicate the purpose of BLUETOOTH communication between devices.

3) Codec: Audio signal compression and conversion format

4) LDAC is an audio coding technology developed by Sony that enables the transmission of High-Resolution (Hi-Res) Audio content, even over a BLUETOOTH connection.

General

Input

HDMI IN*

Outputs

HDMI OUT (TV eARC/ARC)*

S-CENTER OUT

* HDMI IN and HDMI OUT (TV eARC/ARC) jacks support HDCP2.2 and HDCP2.3 protocols. HDCP2.2 and HDCP2.3 are newly enhanced copyright protection technology that is used to protect content such as 4K movies.

Power consumption

On: 13 W

Network standby mode ([Network/Bluetooth Standby] is set to ON): 2.8 W or less

Standby mode ([Network/Bluetooth Standby] is set to OFF): 0.5 W or less*

* When [Signal Pass Through] is set to [Off], or when [Signal Pass Through] is set to [Auto] and the connected TV is turned off.

* If [Signal Pass Through] is set to [On], or if [Signal Pass Through] is set to [Auto] and [Control for HDMI] is set to [Off], the power consumption will exceed the value listed above.

When the [Auto Standby] function is enabled, if the speaker system is not being operated and there is no signal input for about 20 minutes, the control box automatically enters the network standby mode or standby mode.

Disabling the [Auto Standby] function will increase the power consumption of this speaker system.

Dimensions* (approx.) (w/h/d)

160 mm × 56 mm × 160 mm (6 3/8 in × 2 1/4 in × 6 3/8 in)

* Not including projection portion

Mass (approx.)

770 g (1 lb 12 oz)

Wireless Transmitter/Receiver Section

Communication system

Wireless Sound Specification version 4.0

Frequency band

5 GHz

Modulation method

OFDM

Note

- Design and specifications are subject to change without notice.
- Refer to the Reference Guide included with your product, which may contain specification information not listed above.

TP1001054641

5-049-832-11(4) Copyright 2024 Sony Corporation

Supported Audio Formats

The supported audio formats differ depending on the input. “○” indicates a supported audio format and “-” indicates an unsupported audio format in the table below.

Format	HDMI input	TV input (eARC)	TV input (ARC)
LPCM 2ch	○	○	○
LPCM 5.1ch	○	○	-
LPCM 7.1ch	○	○	-
Dolby Digital	○	○	○
Dolby TrueHD	○	○	-
Dolby Digital Plus	○	○	○
Dolby Atmos	○	○	-
Dolby Atmos - Dolby TrueHD	○	○	-
Dolby Atmos - Dolby Digital Plus	○	○	○
DTS	○	○	○
DTS-ES Discrete 6.1, DTS-ES Matrix 6.1	○	○	○
DTS 96/24	○	○	○
DTS-HD High Resolution Audio	○	○	-
DTS-HD Master Audio	○	○	-
DTS:X	○	○	-
360 Reality Audio	○	-	-

Note

- HDMI IN does not support audio formats that contain copy protections, such as Super Audio CD or DVD-Audio.

Home Theatre System
BRAVIA Theatre Quad

Supported HDMI Video Formats

The speaker system supports the following video formats.

8K 24/25/30/50/60 Hz
4K 24/25/30/50/60/100/120 Hz
1440p 120 Hz
1080p 24/30/50/60/100/120 Hz
1080i 50/60 Hz
720p 24/30/50/60 Hz
576p 50 Hz
480p 60 Hz

About the [HDMI Signal Format] setting

When [Settings] - [HDMI Settings] - [HDMI Signal Format] is set to [Enhanced format (4K120, 8K)] on the remote control screen on the app, all the video formats that are supported by the speaker system can be input.

When [HDMI Signal Format] is set to [Enhanced format], the video formats are limited to 4K 60 Hz 4:4:4, 4:2:2, etc.

When [HDMI Signal Format] is set to [Standard format], the video formats are limited to 4K 60 Hz 4:2:0, 4K 24 Hz, etc.

About the HDMI cable to use

Use an HDMI-authorized cable.

Use the supplied HDMI cable to connect to a TV.

An Ultra High Speed HDMI Cable capable 48 Gbps supports all the video formats that are supported by the speaker system.

A Premium High Speed HDMI Cable with Ethernet capable 18 Gbps supports video formats up to 4K 60 Hz 4:4:4, 4:2:2, etc.

About the 3D signal

The following video format is compatible with a 3D signal in the Side-by-Side (Half) format.

- 1080i 50/60 Hz

The following video formats are compatible with a 3D signal in the Frame packing and Over-Under (Top-and Bottom) format.

- 1080p 24 Hz
- 720p 50/60 Hz

About HDMI connection

- The speaker system supports "TRILUMINOS."
- The HDMI jack on the speaker system supports video signals up to 4K 120p/8K, HDR (High Dynamic Range)(*1), VRR(*2), ALLM(*3), SBTM(*4), HDCP2.3(*5), and a wide color gamut in compliance with the ITU-R BT.2020 standard(*6).

Hint

- When the low latency mode is enabled by the ALLM function, some types of sound processing will not be performed to reduce audio delay.

*1 HDR is a video standard that provides vivid images and is capable of representing a wider range of luminance (bright and dark). The speaker system supports HDR10, HLG (Hybrid Log-Gamma), and Dolby Vision.

- *2 VRR (Variable Refresh Rate) is a method of video transmission that can reduce video stuttering and display images smoothly by adjusting the refresh rate on the display to match the frame rate in video games, etc.
- *3 ALLM (Auto Low Latency Mode) is a function that automatically switches to low latency mode in conjunction with the output of video games, etc.
- *4 SBTM (Source-Based Tone Mapping) is a function that allows an AV device to produce and display HDR images that are optimized for the characteristics of a TV.
- *5 HDCP2.3 is a copy protection technology that protects content such as 4K and 8K video content.
- *6 BT.2020 is a wide color gamut standard that is established for Super Hi-Vision TVs.

TP1001174837

5-049-832-11(4) Copyright 2024 Sony Corporation

Home Theatre System
BRAVIA Theatre Quad

Trademarks

LDAC and LDAC logo are trademarks of Sony Group Corporation or its affiliates.

The BLUETOOTH® word mark and logos are registered trademarks owned by Bluetooth SIG, Inc. and any use of such marks by Sony Group Corporation and its subsidiaries is under license.

The terms HDMI™, HDMI High-Definition Multimedia Interface, HDMI Trade dress and the HDMI Logos are trademarks or registered trademarks of HDMI Licensing Administrator, Inc.

Apple, AirPlay, iPad, iPhone, iPod touch and Siri are trademarks of Apple Inc., registered in the U.S. and other countries and regions.

“BRAVIA” and “BRAVIA Sync” are a registered trademark or a trademark of Sony Group Corporation or its affiliates.

Wi-Fi®, Wi-Fi Protected Access® and Wi-Fi Alliance® are registered trademarks of Wi-Fi Alliance. Wi-Fi CERTIFIED™, WPA™, WPA2™, and WPA3™ are trademarks of Wi-Fi Alliance.

“PlayStation” is a registered trademark or trademark of Sony Interactive Entertainment Inc.

“TRILUMINOS” and “TRILUMINOS” logo are a registered trademark of Sony Group Corporation or its affiliates.

Spotify and Spotify logos are registered trademarks of Spotify AB. * * Spotify service may not be available in some countries/regions. Please visit support.spotify.com for more information.

All other trademarks and registered trademarks are trademarks or registered trademarks of their respective holders. In this manual, TM and ® marks are not specified.

HDMI™
HIGH-DEFINITION MULTIMEDIA INTERFACE

TP1001054638

Home Theatre System
BRAVIA Theatre Quad

Licenses

Dolby, Dolby Vision, Dolby Atmos, and the double-D symbol are registered trademarks of Dolby Laboratories Licensing Corporation. Manufactured under license from Dolby Laboratories. Confidential unpublished works. Copyright © 2012–2021 Dolby Laboratories. All rights reserved.

Manufactured under license from IMAX Corporation. IMAX® is a registered trademark of IMAX Corporation in the United States and/or other countries. For DTS patents, see <http://patents.dts.com>. Manufactured under license from DTS, Inc. or DTS Licensing Limited. DTS, DTS:X, and the DTS:X logo are registered trademarks or trademarks of DTS, Inc. in the United States and other countries. © 2021 DTS, Inc. ALL RIGHTS RESERVED.

Use of the Works with Apple AirPlay badge means that an accessory has been designed to work specifically with the technology identified in the badge and has been certified by the developer to meet Apple performance standards.

This product contains software that Sony uses under a licensing agreement with the owner of its copyright. We are obligated to announce the contents of the agreement to customers under requirement by the owner of copyright for the software. Please access the following URL and read the contents of the license.

<https://rd1.sony.net/help/ht/sl/23c/>

The software included in this product contains copyrighted software that is licensed under the GPL/LGPL and other licenses which may require access to source code. You may find a copy of the relevant source code as required under the GPL/LGPL (and other licenses) at the following URL. You may obtain the source code as required by the GPL/LGPL on a physical medium from us for a period of three years after our last shipment of this product by applying through the form at the following URL. This offer is valid to anyone in receipt of this information.

<https://oss.sony.net/Products/Linux/>

Please note that Sony cannot answer or respond to any inquiries regarding the content of this source code.

The Spotify Software is subject to third party licenses found here:

<https://www.spotify.com/connect/third-party-licenses>.

Disclaimer regarding services offered by third parties

Services offered by third parties may be changed, suspended, or terminated without prior notice. Sony does not bear any responsibility in these sorts of situations.

TP1001054637

Notes on Use

Precautions

- Before using the speaker system, check that the operating voltage matches your local supply voltage. The operating voltage is indicated on the nameplate attached to the bottom of the speaker system.
- The supplied AC adaptor is designed exclusively for this speaker system. It should not be used with any other device.
- The supplied AC power cord (mains lead) is designed exclusively for this speaker system. It should not be used with any other device.
- Unplug the AC adaptor(*) and AC power cords (mains leads) from the AC outlets (mains) when the speaker system is not being used for long periods of time. When unplugging the AC adaptor(*) and AC power cords (mains leads) from the AC outlets (mains), always unplug them by holding the plug. Never pull the cord itself.
- AC adaptor(*) and AC power cord (mains lead) must only be changed at a qualified service shop.

* North American models only

On placement

- If a foreign object or water gets into the speaker system, unplug the speaker system from the AC outlet (mains), and have it checked by qualified personnel before continuing use.
- Do not place the speaker system near heat sources or in a location subject to direct sunlight, excessive dust, or mechanical shock. These conditions may cause malfunction.
- The speakers of the speaker system are not the magnetically shielded type. Do not place magnetic cards on the speaker system or near it.
- Do not place metal objects other than a TV around the speaker system. Wireless functions may become unstable.
- When the speaker system is used with a tuner, TV, or VCR, noise or distorted images may be produced. In this case, install the speaker system away from these devices.
- Do not place the speaker system near objects that emit a strong magnetic field, such as microwave ovens or large speakers.
- The temperature of the speaker system may rise during use. This is not a malfunction.
- If the ventilation holes on the speaker system are blocked, the temperature inside the speaker system will rise considerably. This may cause malfunction. Ensure that the ventilation holes are never blocked.
- Placing the speaker system on a floor that is coated with special paint, wax, grease, or solvent, etc. may result in discoloration or stains on the floor.

How to care for the speaker system

- Clean the speaker system with a soft cloth lightly dampened with neutral detergent. Do not use any type of abrasive pad, scouring powder, or solvent such as alcohol or benzene.

On BLUETOOTH communications

- BLUETOOTH wireless technology is a short-range wireless technology that enables communication between digital devices such as smartphones and computers. The maximum communication range may vary depending on the presence of obstacles (people, metal objects, walls, etc.) or the electromagnetic environment.
- Microwaves that are generated by a BLUETOOTH device may affect the operation of electronic medical devices. Turn off the speaker system and other BLUETOOTH devices in the following locations, as it may cause an accident:
 - In hospitals, near priority seating on trains, locations where inflammable gas is present, near automatic doors, or near fire alarms.
- The speaker system supports security functions that comply with the BLUETOOTH security standard during communication using BLUETOOTH wireless technology. However, depending on the configured settings and other

factors, this security may be insufficient. Be careful when using BLUETOOTH communication.

- Sony shall assume no responsibility for any damages or loss resulting from data leaks that may occur when using BLUETOOTH communications.
- BLUETOOTH connection is not guaranteed to work with all BLUETOOTH devices.
 - BLUETOOTH devices being connected with the speaker system must comply with the BLUETOOTH standard prescribed by Bluetooth SIG, Inc. and must be certified as compliant.
 - Even when a connected device complies with the above BLUETOOTH standard, depending on the characteristics and specifications of the device, it may not be able to connect, or the operation method, display, or operation may differ.
- Noise may occur or the audio may cut out depending on the BLUETOOTH device that is connected with the speaker system, the communications environment, or surrounding conditions.
- Depending on the connected device, it may take some time for communications to start.

Other notes

- When connecting the speaker system to the Internet, connect it via a router(*) with the appropriate security settings. If there is a security issue, the speaker system may be subject to malware (malicious software) attacks, etc. over the internet. Your information and digital assets may be exposed to threats such as extraction and falsification. The speaker system may also damage other network services without your knowledge.

* A router is a device that relays between the internet and a local network line.

There are the following types of routers:

- Wired router
- ADSL modem with router function
- Optical network unit (ONU) with router function
- Wi-Fi access point with router function (wireless LAN router)
- Wall socket (wall outlet) device with network line (**)

** If you are uncertain whether a wall socket (wall outlet) device with a network line has a router function, check with the manager of the housing complex or the internet provider.

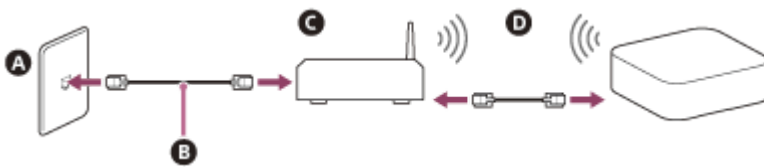

- A LAN terminal in the wall**
- B LAN cable**
- C Router**
- D LAN cable or Wireless LAN**

Note

- Check that the router is turned on.
 - Check the network connection and network settings.
 - When a wireless LAN router is being used, the communication range may become shorter depending on the usage environment (including the wall material), radio wave reception conditions, or obstacles between the speaker system and wireless LAN router. Move the speaker system and wireless LAN router closer to each other.
 - Devices that use a 2.4 GHz frequency band, such as microwaves, BLUETOOTH devices, or digital cordless devices, may interrupt communication. Move the speaker system away from such devices or turn them off.
 - A wireless LAN connection may become unstable depending on the usage environment, especially while the BLUETOOTH function is being used on the speaker system. Try to improve your wireless LAN usage environment.
- If you have any questions or problems concerning this speaker system, please consult your nearest Sony dealer.

Home Theatre System
BRAVIA Theatre Quad

Customer Support Website

Visit the customer support website in your country or region in the following situations.

- When you have a question about the speaker system.
- When you have an issue with the speaker system.
- When you want information on compatible items.

For customers in the USA, Canada and Latin America:

<https://www.sony.com/am/support>

For customers in Europe:

<https://www.sony.eu/support/>

For customers in Mainland China:

<https://service.sony.com.cn/>

For customers in Asia-Pacific, Oceania, the Middle East and Africa:

<https://www.sony-asia.com/support>

TP1001054635